

Shipping: 123 Pawnook Farm Road • Lenoir City TN 37771
Mailing: P.O. Box 370 • Kingston TN 37763

Phone: (865) 882-5860
Fax: (865) 882-6394
Website: www.BargerAndSons.com

Protecting the environment one tank at a time since 1967.

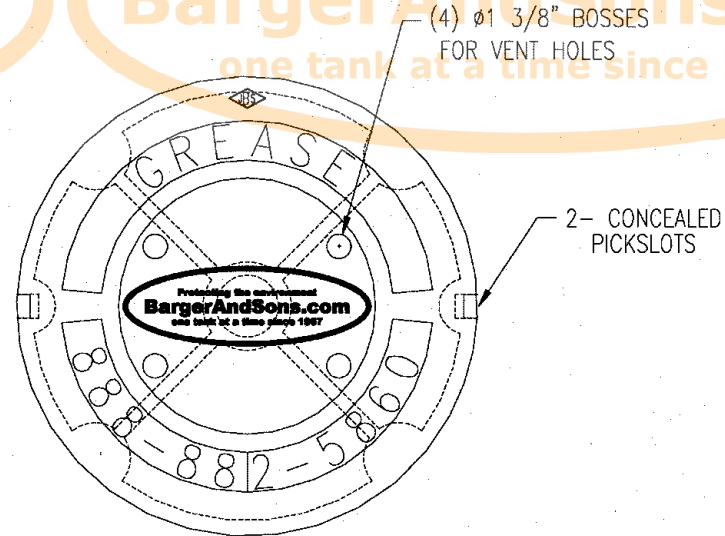
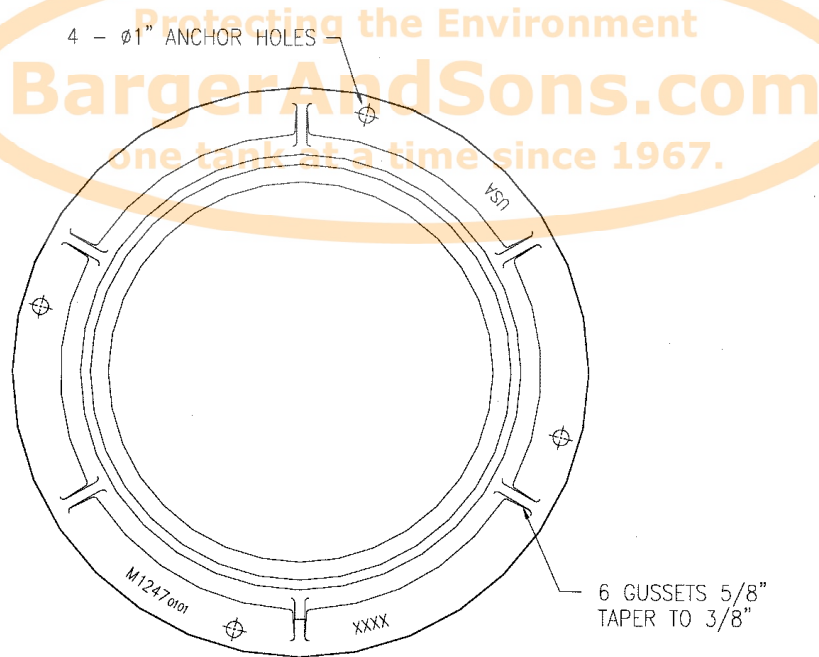

| | |
|--------------------------------|----------------------------------|
| Manhole Frame and Cover | |
| Height | 7" |
| Clear Opening | 24" |
| Estimated Weight | Frame: 310 lbs |
| Load Rating | Heavy Duty H-20 Traffic Rated |
| Lid Type | Solid (Non-vented) |

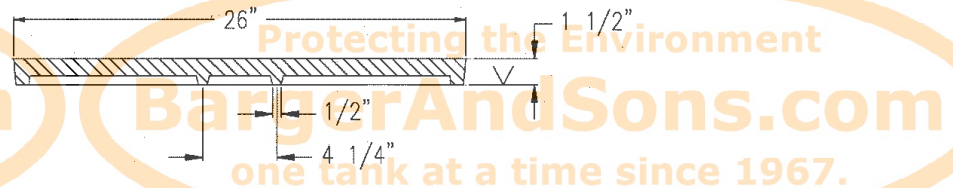
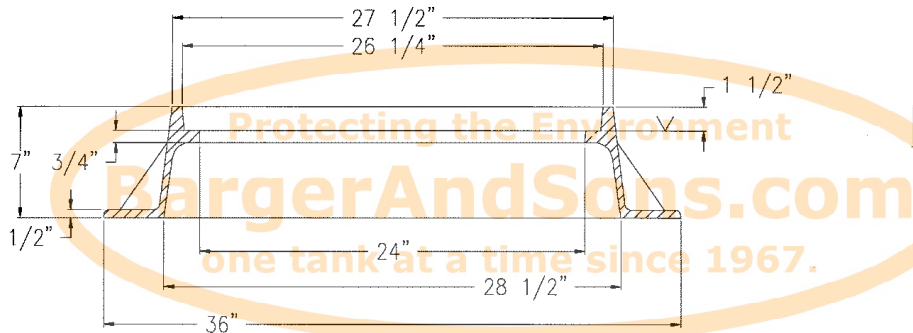

Shipping: 123 Pawnook Farm Road • Lenoir City TN 37771

Mailing: P.O. Box 370 • Kingston TN 37763

Phone: (865) 882-5860

Fax: (865) 882-6394

Website: www.BargerAndSons.com

Protecting the environment one tank at a time since 1967.

Protecting the Environment

BargerAndSons.com

one tank at a time since 1967.

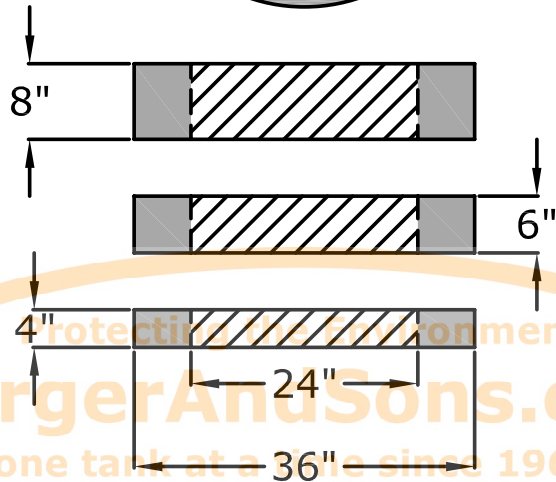
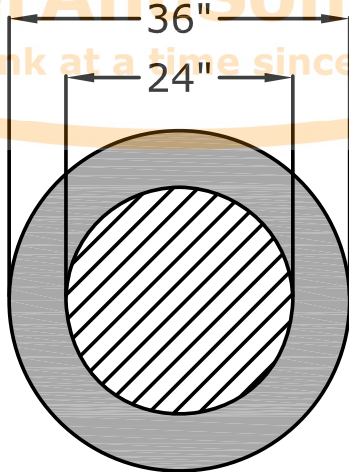

Protecting the Environment

BargerAndSons.com

one tank at a time since 1967.

Grade Ring

Height

4", 6", or 8" tall

Clear Opening

24"

Estimated Weight

4": 195 lbs

6": 290 lbs

8": 390 lbs

Load Rating

Heavy Duty

HS-20 Traffic Rated

Type

Precast Concrete

Protecting the Environment

BargerAndSons.com

one tank at a time since 1967.

Certificate of Conformance

Date: March 23, 2006

This is to certify that the material listed below conforms to the following specifications. The material meets or exceeds the listed performance requirements.

Product: CS-665 Non-Toxic Butyl Sealant

Performance: Tested in compliance to the conditions specified in the Federal Hazardous Substance Act (16 CFR 1500). Test results conclusively show that CS-665 is classified as non-toxic by oral administration.

Specifications: This product meets or exceeds the requirements of ANSI/NSF Standard 61.

Chemical Composition and Properties:

| | |
|--|--------------|
| Volatile matter % by weight (ASTM D6): | 13% |
| Specific Gravity (ASTM D71) | 1.30 – 150. |
| Ductility (ASTM D113) | 5.0 min. |
| Penetration @ 77° (ASTM D217) | 50 – 120 dmm |

Sincerely,

Tim Frazier

Tim Frazier
Technical Director