

Top View

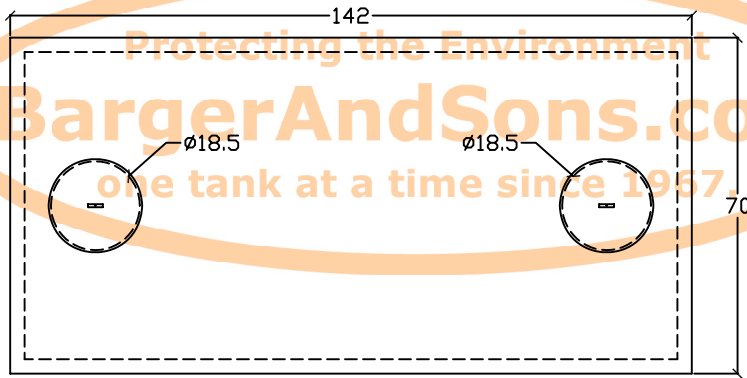

End View

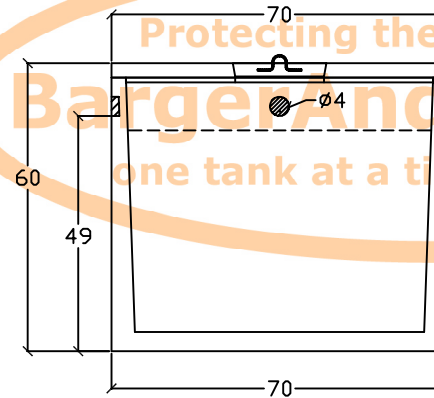

Side View

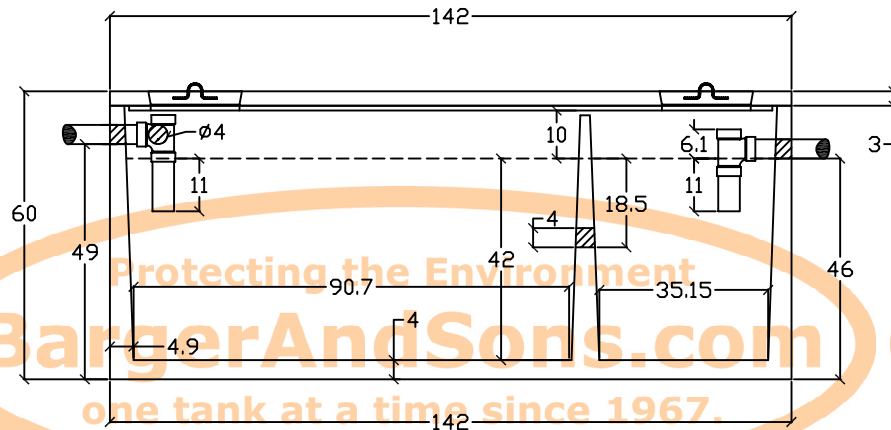

Baffle View

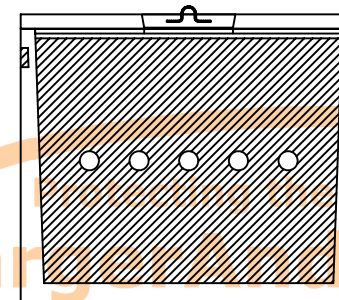

Specifications

Concrete: 4,000 psi minimum strength (28 day)

Reinforcing: Primary reinforcement will be a #3 rebar (Grade 60) rebar cage that will reinforce the top, side, baffle wall, and bottom. The rebar will be on 18" centers (width and length) in the walls, bottom, and baffle walls. The rebar will be on 12" centers (length and width) in the top. All splices will be overlapped six inches. Structural reinforcing Forta fiber (3 lb/yd3) will also be used as a secondary reinforcement.

Risers: All risers, if required, will be watertight and will support a 2500 lb. wheel load.

Sealant: Sealant used in the seam of the tank will meet or exceed ASTM C990.

Pipe Penetrations: Inlet and outlets are fitted with seals that meet or exceed all ASTM C923 specifications.

Baffle Wall: The baffle wall is poured monolithically.

Tank Label: On the end of the tank, above and to the right of the outlet, the tank label will read "CRB 1500".

Manufactured by:
C.R. Barger & Sons, Inc.
 238 Mays Valley Road
 Harriman Tn 37748
Phone 865.882.5860 **Fax** 865.882.6394
 www.bargerandsons.com

General Notes:
 All vertical measurements are accurate within ± 1 inch on the tank. The lids can be moved and resized if necessary. Written specifications are available upon request.

Tank Type: Septic Tank 1500 Gallon	
Date: 3.292005	Approx. Weight: 15,000 lbs.
Drawn By: Eric Barger	State: Georgia