

Top View

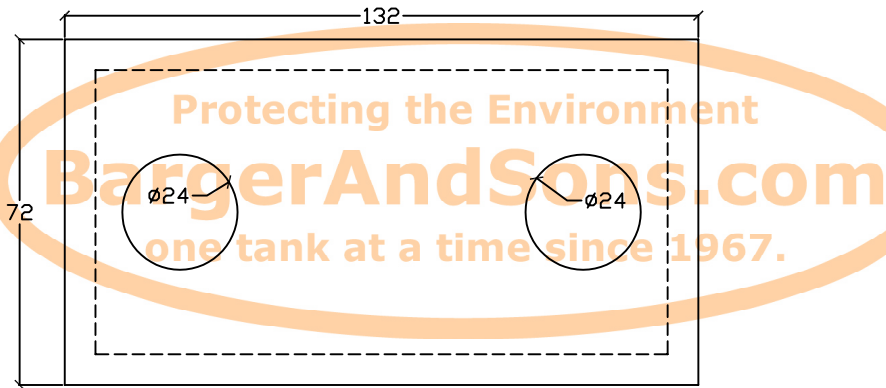

End View

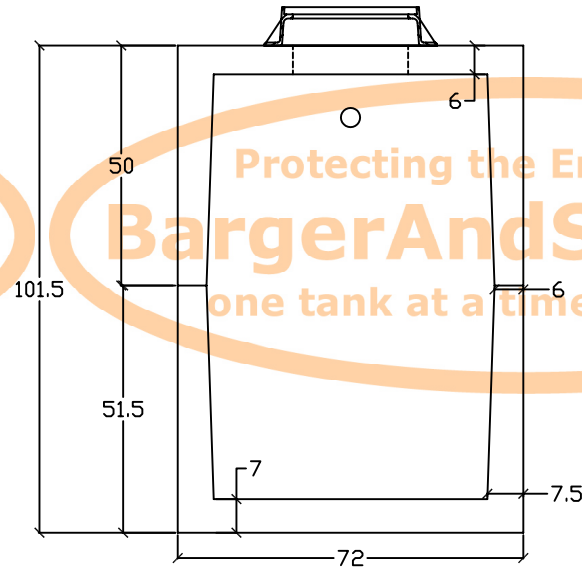

**Specifications**

**Concrete:** 5,000 psi minimum strength (28 day)

**Reinforcing:** Primary reinforcement will be #5 and #7 rebar (Grade 60) in compliance with the engineer reinforcement detail. All splices will be overlapped 40 bar diameters.

**Risers:** All risers will support H-20 traffic ratings.

**Sealant:** Sealant used in the seam of the tank will meet or exceed ASTM C990.

**Pipe Penetrations:** Inlet and outlets are fitted with seals that meet or exceed all ASTM C923 specifications.

**Baffle Wall:** The baffle wall is poured monolithically.

**Tank Label:** On the end of the tank, above and to the right of the outlet, the tank label will read "CRB 2500".

Side View

East Jordan 1047Z, 24" clear opening, H20 Manhole Frame and Cover. Lid is labeled "Grease". Please specify vented or nonvented lid.

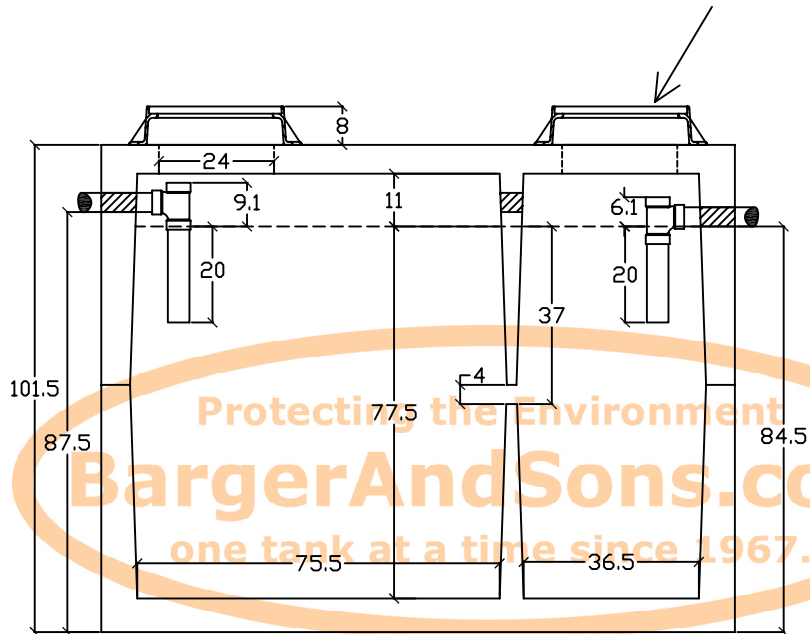

Baffle View

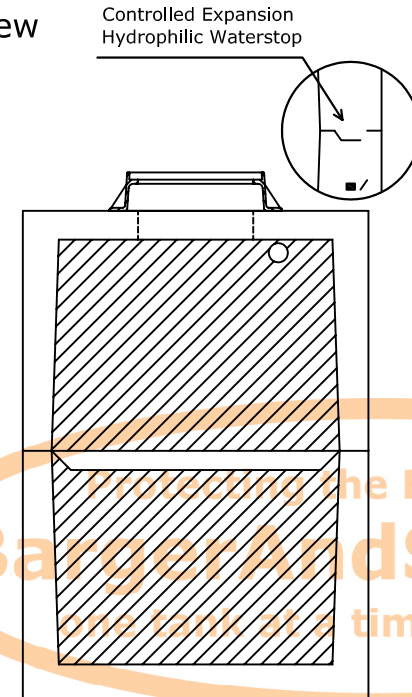

Manufactured by:  
**C.R. Barger & Sons, Inc.**  
 238 Mays Valley Road  
 Harriman Tn 37748  
**Phone** 865.882.5860 **Fax** 865.882.6394  
 www.bargerandsons.com

General Notes:  
 All vertical measurements are accurate within ± 1 inch on the tank. The lids can be moved and resized if necessary. Written specifications and engineered drawings are available upon request. Tank is designed for a maximum cover of 8' and H-20 loadings.

Tank Type:	Septic Tank H-20 2500 Gallon	
Date:	3.302005	Approx. Weight: 32,000 lbs.
Drawn By:	Eric Barger	State: Georgia