

Top View

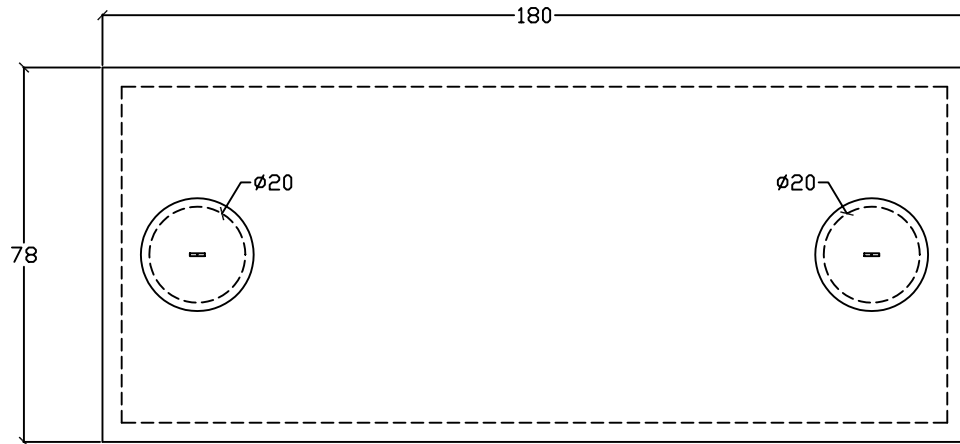

End View

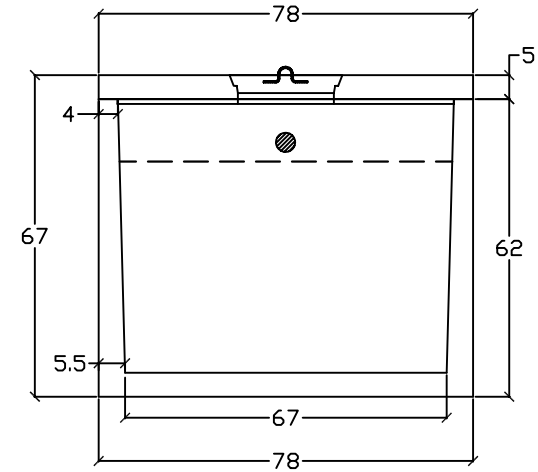

Side View

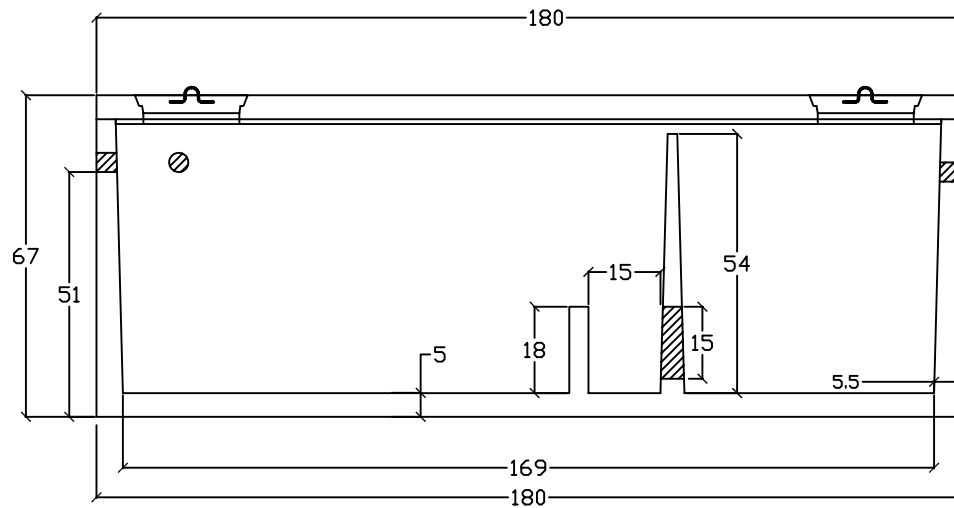

Baffle View

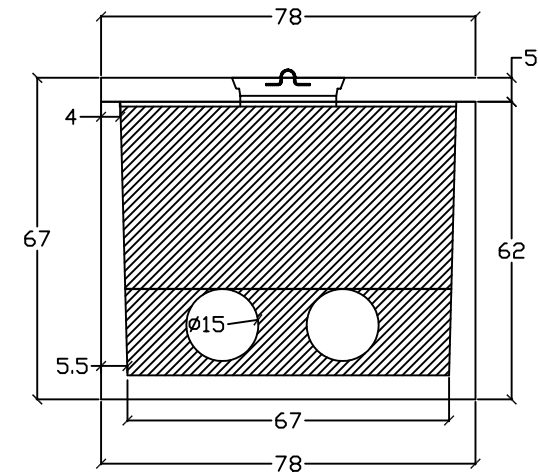

Manufactured by:  
**C.R. Barger & Sons, Inc.**  
 238 Mays Valley Road  
 Harriman Tn 37748  
 Phone 865.882.5860 Fax 865.882.6394

General Notes:  
 All vertical measurements are accurate within  $\pm 1$  inch on the tank. The lids can be moved and resized if necessary. Written specifications are available upon request.

Tank Type: <b>Oil/Grit Separator 2100 Gallon</b>	
Date: <b>8.212004</b>	Approx. Weight: <b>27,000 lbs.</b>
Drawn By: <b>Eric Barger</b>	