

Top View

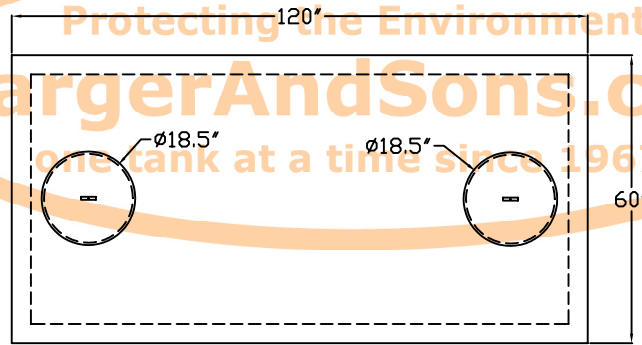

End View

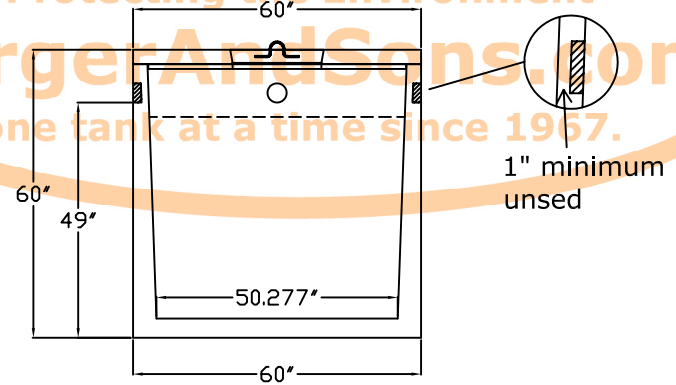

Side View

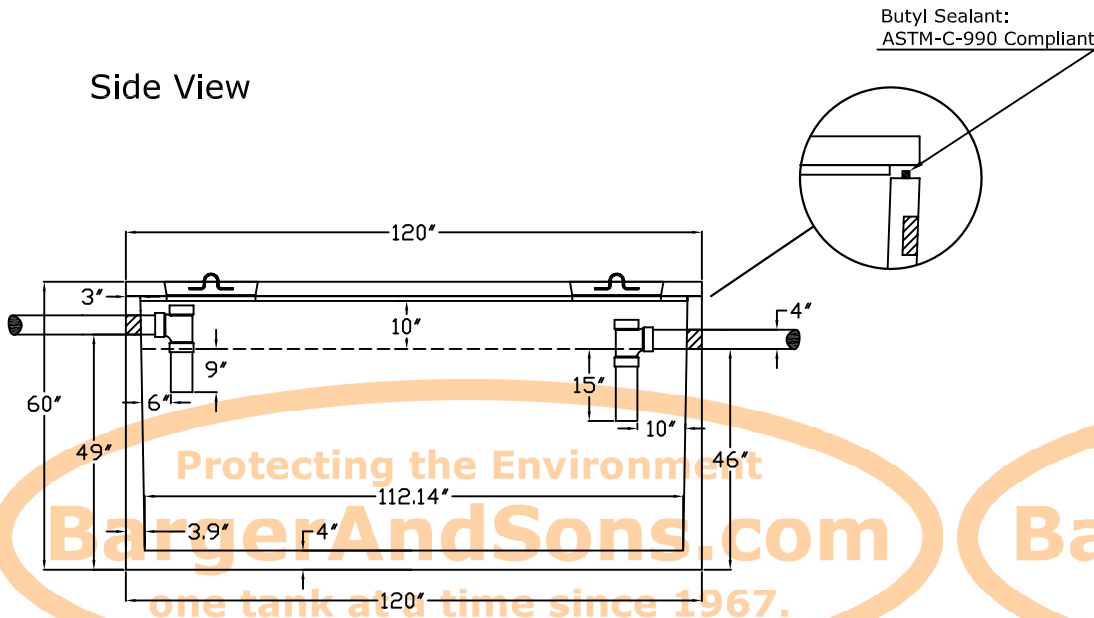

Manufactured by:  
**C.R. Barger & Sons, Inc.**  
 238 Mays Valley Road  
 Harriman Tn 37748  
**Phone** 865.882.5860 **Fax** 865.882.6394  
 www.bargerandsons.com

General Notes:  
 All vertical measurements are accurate within  $\pm 1$  inch on the tank. The lids can be moved and resized if necessary. Written specifications are available upon request.

Tank Type: <b>Septic Tank 1000 Gallon Single Compart.</b>	
Date: <b>8.182004</b>	Approx. Weight: <b>10,000 lbs.</b>
Drawn By: <b>Eric Barger</b>	State Compliance: <b>Kentucky</b>