

Top View

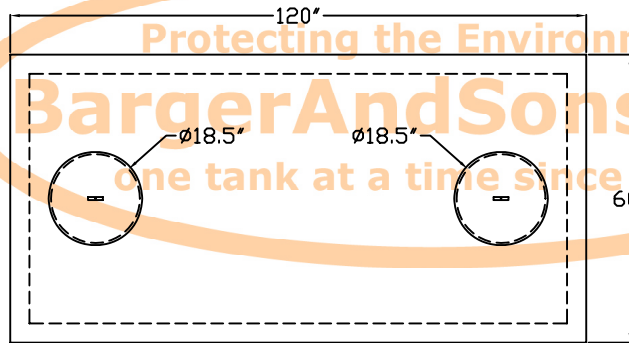

End View

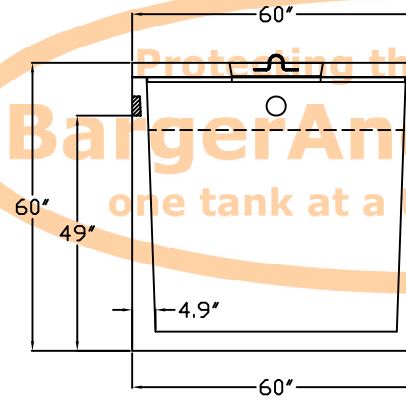

Side View

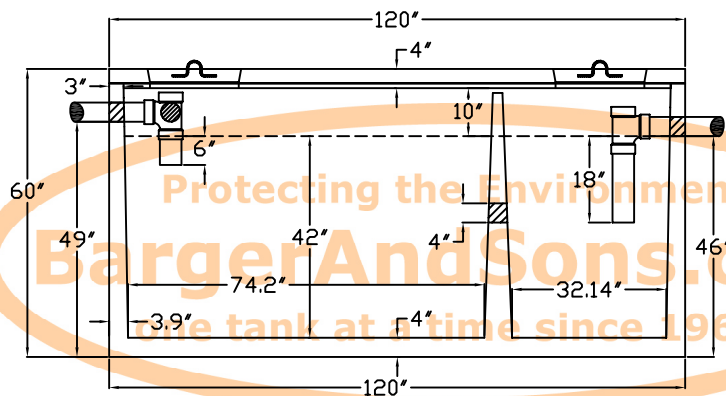

Butyl Sealant:
ASTM-C-990 Compliant

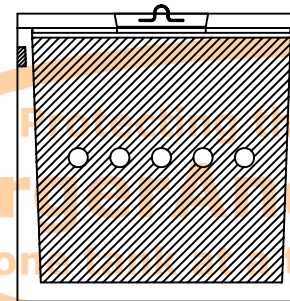
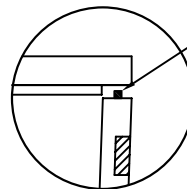

Specifications

Concrete: 5,000 psi minimum strength (28 day)

Structural Performance: The tank meets the design criteria of one hundred fifty pounds per square foot (150 lb/ft²) uniform loading on the top of the tank with a maximum backfill cover of 36" and a minimum of 6".

Reinforcing: Primary reinforcement will be a #3 rebar (Grade 60) rebar cage that will reinforce the top, side, baffle wall, and bottom. The rebar will be on 18" centers (width and length) in the walls, bottom, and top. All splices will be overlapped six inches. Structural reinforcing Forta fiber (3 lb/yd³) will also be used as secondary reinforcement.

Risers: All risers, if required, will be watertight and at least 24" in diameter.

Sealant: Sealant used in the seam of the tank will meet or exceed ASTM C990.

Pipe Penetrations: Inlet and outlets are fitted with seals that meet or exceed all ASTM C923 specifications.

Baffle Wall: The baffle wall, if present, is poured monolithically.

Tank Label: On the end of the tank, above and to the right of the outlet, the company logo and capacity in gallons will be cast into the tank.

Manufactured by:
C.R. Barger & Sons, Inc.
238 Mays Valley Road
Harriman Tn 37748
Phone 865.882.5860 **Fax** 865.882.6394
www.bargerandsons.com

General Notes:
All vertical measurements are accurate within ± 1 inch on the tank. The lids can be moved and resized if necessary. Written specifications are available upon request.

Tank Type: Septic 1000 Gallon Two Compartment	
Date: 4.122005	Approx. Weight: 10,000 lbs.
Drawn By: Eric Barger	State: Mississippi