

Top View

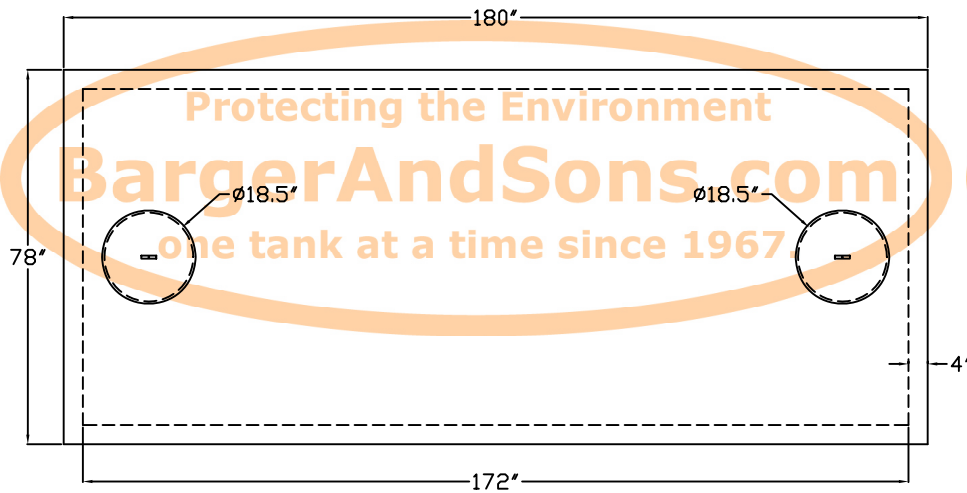

End View

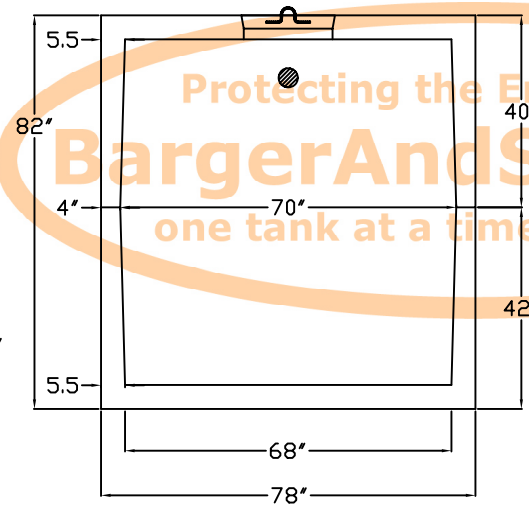

Side View

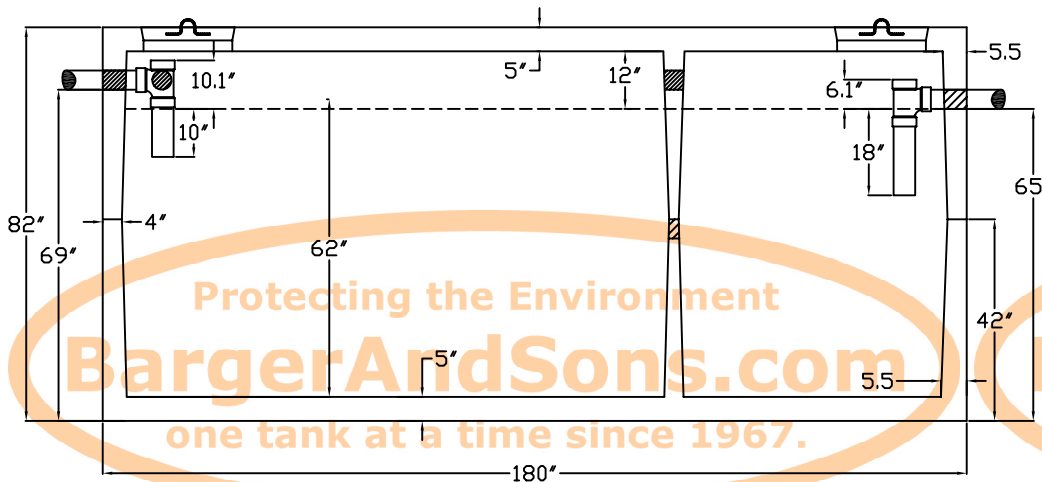

Baffle View

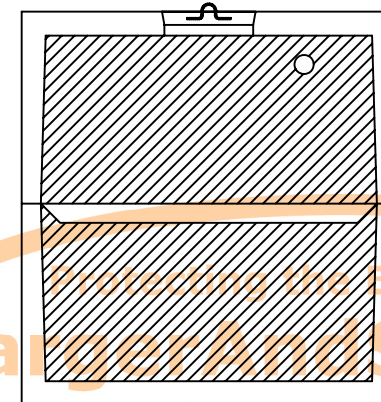

**Specifications**

**Concrete:** 5,000 psi minimum strength (28 day)

**Reinforcing:** Primary reinforcement will be #3 and #4 rebar (Grade 60) on 18" centers.

**Risers:** Risers over each access port will be 24" diameter and brought to finished grade.

**Sealant:** Sealant used in the seam of the tank is a controlled expansion hydrophillic waterstop.

**Pipe Penetrations:** Inlet and outlets are fitted with seals that meet or exceed all ASTM C923 specifications.

**Baffle Wall:** The baffle wall is poured monolithically with the tank walls and bottom for each half respectively.

**Tank Label:** On the end of the tank, above and to the right of the outlet, the tank label will read "CRB 3000".

Manufactured by:  
**C.R. Barger & Sons, Inc.**  
 238 Mays Valley Road  
 Harriman Tn 37748  
**Phone** 865.882.5860 **Fax** 865.882.6394  
 www.bargerandsons.com

General Notes:  
 All vertical measurements are accurate within ± 1 inch on the tank. The lids can be moved and resized if necessary. Written specifications are available upon request.

Tank Type: <b>Septic Tank 3000 Gallon Mid-Seam</b>	
Date: <b>3.072005</b>	Approx. Weight: <b>29,000 lbs.</b>
Drawn By: <b>Eric Barger</b>	State: <b>Ohio</b>