

Top View

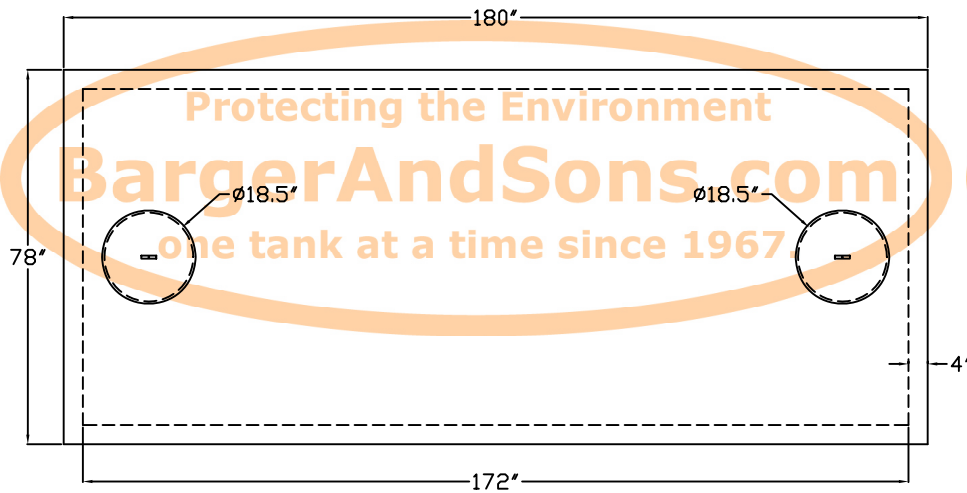

End View

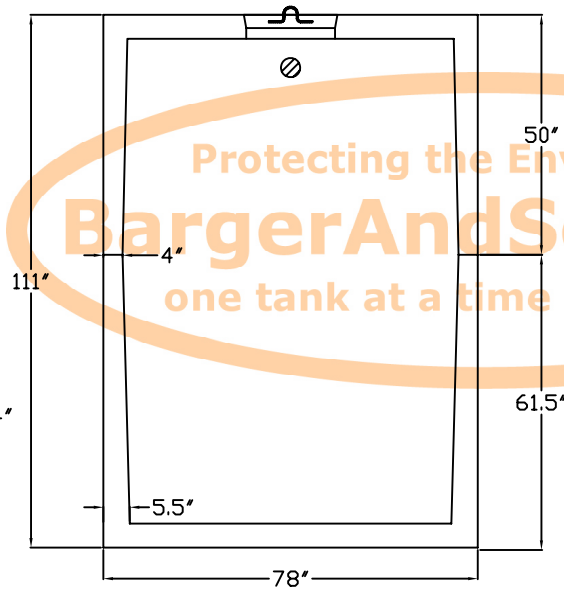

Specifications

Concrete: 5,000 psi minimum strength (28 day)

Reinforcing: Primary reinforcement will be #3 and #4 rebar (Grade 60) on 18" centers.

Risers: Risers over each access port will be 24" diameter and brought to finished grade.

Sealant: Sealant used in the seam of the tank is a controlled expansion hydrophillic waterstop.

Pipe Penetrations: Inlet and outlets are fitted with seals that meet or exceed all ASTM C923 specifications.

Baffle Wall: The baffle wall is poured monolithically with the tank walls and bottom for each half respectively.

Tank Label: On the end of the tank, above and to the right of the outlet, the tank label will read "CRB 4500".

Side View

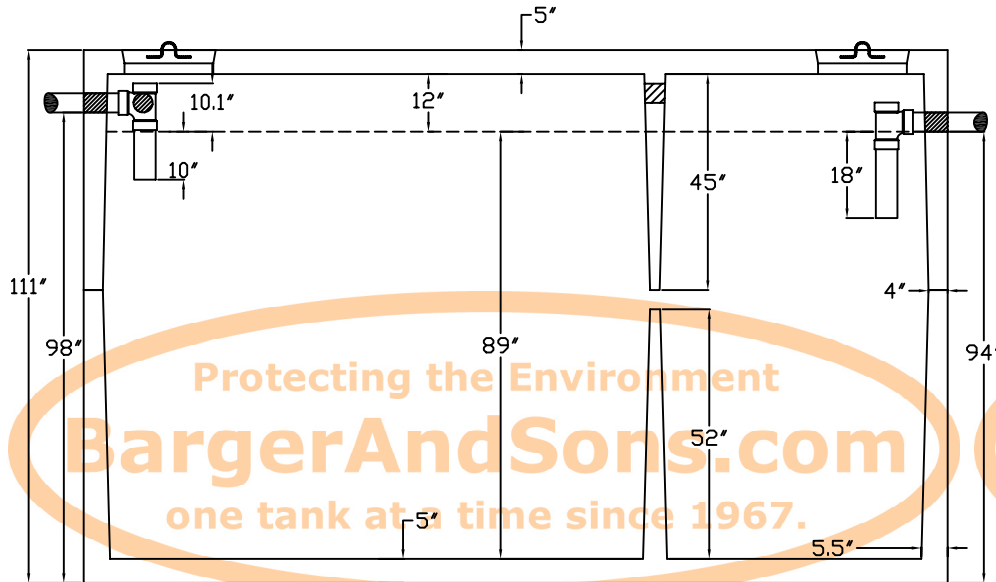

Baffle View

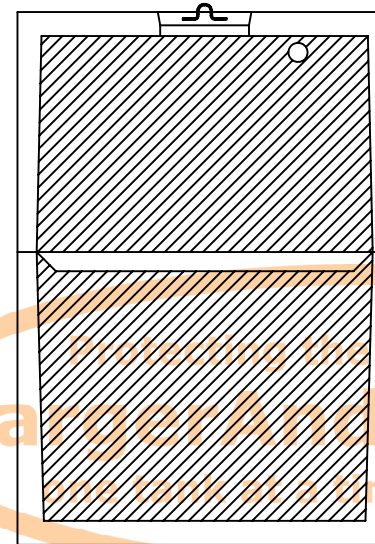

Manufactured by:
C.R. Barger & Sons, Inc.
 238 Mays Valley Road
 Harriman Tn 37748
Phone 865.882.5860 **Fax** 865.882.6394
 www.bargerandsons.com

General Notes:
 All vertical measurements are accurate within ± 1 inch on the tank. The lids can be moved and resized if necessary. Written specifications are available upon request.

Tank Type:	Septic Tank 4500 Gallon Mid-Seam	
Date:	3.072005	Approx. Weight: 36,000 lbs.
Drawn By:	Eric Barger	State: Ohio