

Top View

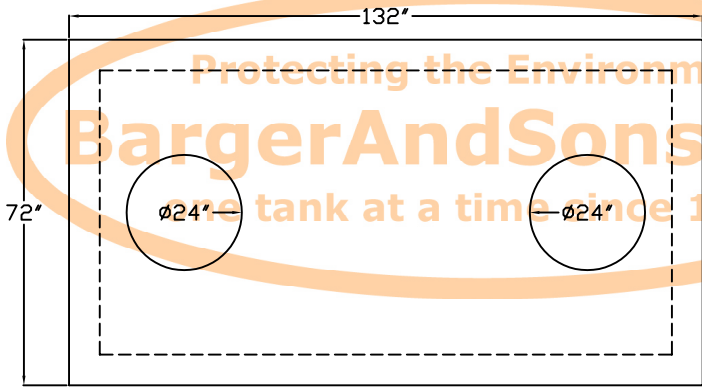

End View

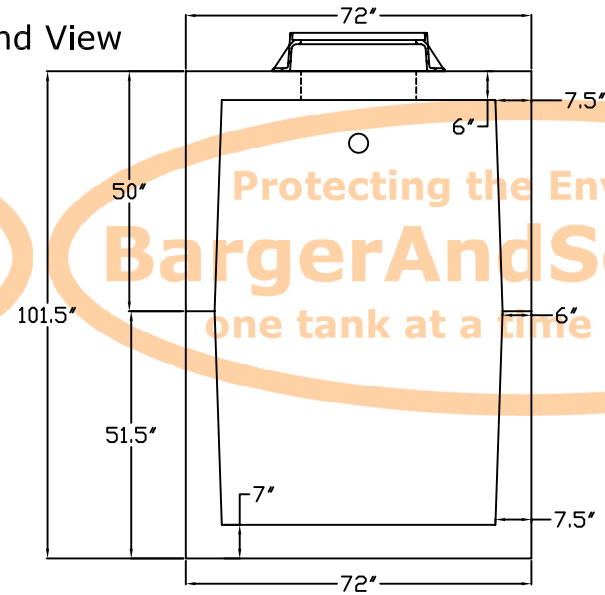

Specifications

Concrete: 5,000 psi minimum strength (28 day)

Reinforcing: Primary reinforcement will be #5 and #7 rebar (Grade 60) in compliance with the engineer reinforcement detail. All splices will be overlapped 40 bar diameters.

Risers: All risers will support H-20 traffic ratings.

Sealant: Sealant used in the seam of the tank will meet or exceed ASTM C990.

Pipe Penetrations: Inlet and outlets are fitted with seals that meet or exceed all ASTM C923 specifications.

Warranty: Tank is guaranteed for two years from date of installation against failure due to poor workmanship and materials of the manufacturer.

Tank Identification: "CRB 2500" and the date of manufacture will be cast or engraved on the outlet end of the tank within 6" of the top of the tank.

Side View

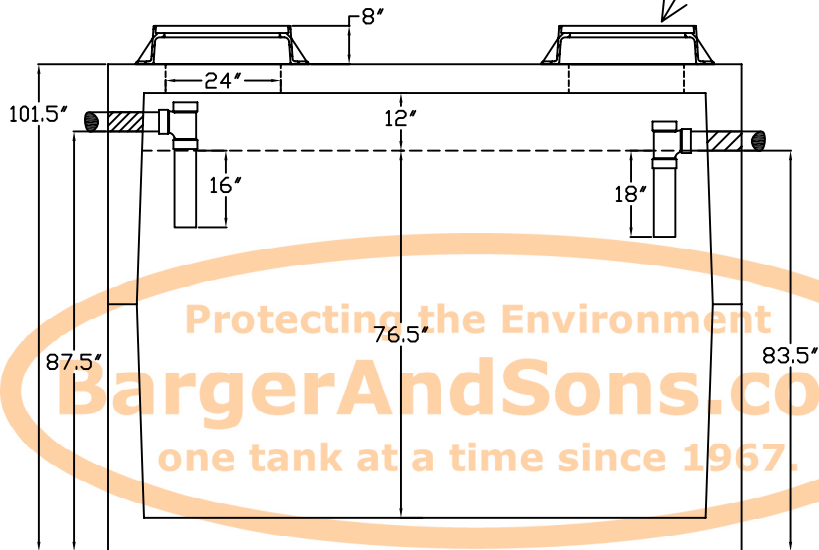

Baffle View



Manufactured by:
C.R. Barger & Sons, Inc.
 238 Mays Valley Road
 Harriman Tn 37748
 Phone 865.882.5860 Fax 865.882.6394
 www.bargerandsons.com

General Notes:
 All vertical measurements are accurate within ± 1 inch on the tank. The lids can be moved and resized if necessary. Written specifications and engineered drawings are available upon request. Tank is designed for a maximum cover of 8' and H2O loadings.

Tank Type:	Septic Tank 2500 Gallon H-20 Traffic Rated	
Date:	4.012005	Approx. Weight: 32,000 lbs.
Drawn By:	Eric Barger	State: South Carolina