

**Top View**

- 4" inlet/outlet (standard)
- 2/3 - 1/3 compartment capacity

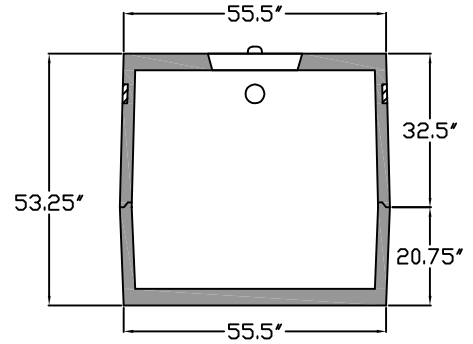

**End View**

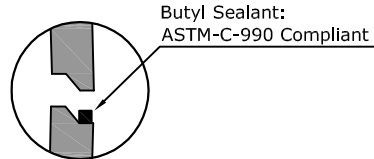

Both the inlet and outlet feature a high pressure pipe seal that will meet the Vacuum & Hydrostatic pressure requirements of A.S.T.M. spec. C-923 for 2", 3" & 4" SCHD.40.

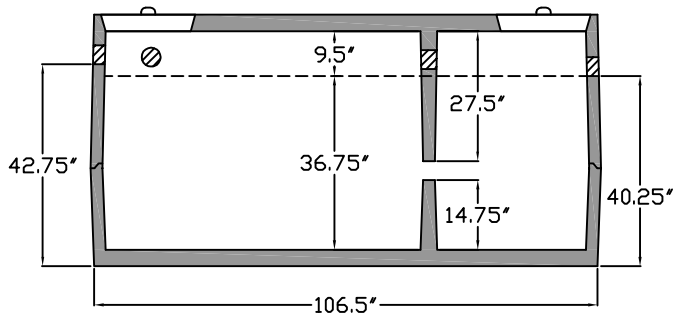

**Side View**

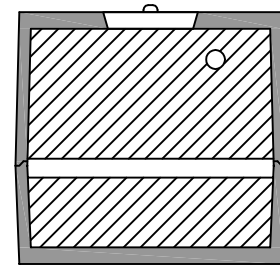

**Baffle View**

**Specifications**

**Concrete:** 5,000 psi minimum strength (28 day)  
**Reinforcing:** Primary reinforcement will be rebar.  
**Risers:** Grade rings and manhole frames and covers sold separately.  
**Sealant:** Sealant used in the seam of the tank will meet or exceed ASTM C990.  
**Pipe Penetrations:** Inlet and outlets are fitted with seals that meet or exceed all ASTM C923 specifications.  
**Partition Wall:** The partition wall, if present, is poured monolithically.  
**Wateright:** ASTM C 1227 latest revision. Tank must be tested within 3 working days of delivery.  
**Drawing:** All measurements are accurate within ± 1 inch.

**Tank Warranty:** When installed in accordance with manufacturer's instructions is warranted against defective materials and/or workmanship for 1 year from the date of delivery to the project site. Should a defect appear within the warranty period, C. R. Barger & Sons, Inc. will supply a new tank in replacement thereof. C. R. Barger & Sons, Inc. liability is limited to the value of the tank itself and specifically excludes the cost of installation and/or removal and consequential damages. Failure to comply with C. R. Barger & Sons, Inc. installation procedures and general notes will void warranty.

**Installation:** The tank hole is not to be more than 18 in. longer and wider than the tank. There shall be a minimum of 6" of 3/4" stone bedding. Do not install across path of vehicles or heavy equipment. This tank is designed for one hundred fifty pounds per square foot (150 lb/ft<sup>2</sup>) uniform loading on the top of the tank with a max backfill cover of 36" and a minimum of 6".



**Septic Tank 750 Gallon Mid-Seam**

**C.R. Barger & Sons, Inc.**  
 P.O. Box 370 - Kingston TN 37763  
 Phone 888.882.5860 - BargerAndSons.com

Date: 5.102010

Drawn By: Eric Barger

Approx. Weight: 7,500 lbs.