

Top View

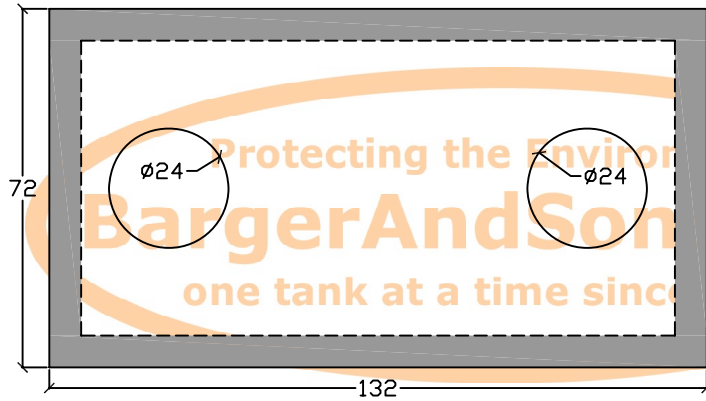

End View

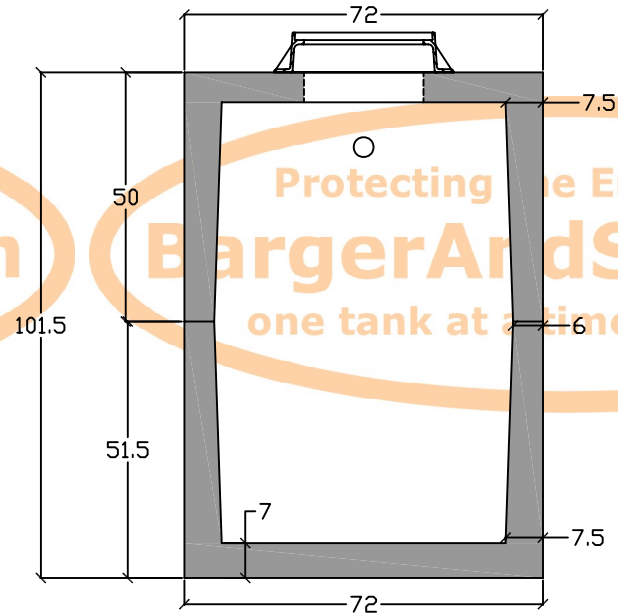

Specifications

Concrete: 5,000 psi minimum strength (28 day)

Reinforcing: Rebar reinforcement is per engineers design. This tank is designed for eight foot of cover and H-20 traffic ratings. Structural engineering drawings stamped by a Licensed Professional Engineer available upon request.

Risers: Grade rings and manhole frames and covers sold separately.

Sealant: Sealant used in the seam of the tank will meet or exceed ASTM C990.

Pipe Penetrations: Inlet and outlets are fitted with seals that meet or exceed all ASTM C923 specifications.

Partition Wall: The partition wall, if present, is poured monolithically.

Installation: The tank hole is not to be more than one foot longer and wider than the tank. There shall be a minimum of 6" of $\frac{3}{4}$ " stone bedding in soil terrain and a 12" stone bedding in rock terrain.

Tank Warranty: The C. R. Barger & Sons, Inc. septic tank when installed in accordance with manufacturer's instructions is warranted against defective materials and/or workmanship for 1 year from the date of delivery to the project site. Should a defect appear within the warranty period, C. R. Barger & Sons, Inc. will supply a new septic tank in replacement thereof. C. R. Barger & Sons, Inc. liability is limited to the value of the septic tank itself and specifically excludes the cost of installation and/or removal and consequential damages.

Failure to comply with C. R. Barger & Sons, Inc. installation procedures and general notes will void warranty.



24" clear opening, H2O Manhole Frame and Cover. Lid is labeled "Grease". Please specify vented or nonvented lid.

Side View

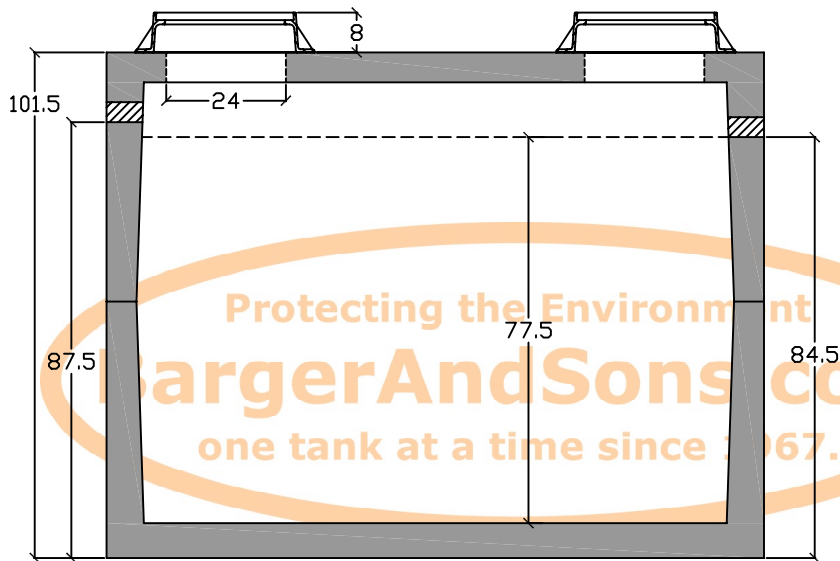

ASTM C990 Butyl Sealant

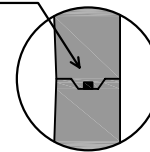

H-20 & HS-20
Traffic Rated

Structural Design
per ASTM 1613

Manufactured by:
C.R. Barger & Sons, Inc.
123 Pawnook Farm Road
Lenoir City TN 37771
Phone 865.882.5860 Fax 865.882.6394
www.BargerAndSons.com

General Notes:
All vertical measurements are accurate within ± 1 inch on the tank. The lids can be moved and resized if necessary. Written specifications and engineered drawings are available upon request. Tank is designed for a maximum cover of 8' and H2O loadings.

Tank Type: Decontamination Tank 2500 Gallon

Date: 8.272009

Approx. Weight: 32,000 lbs.

Drawn By: Eric Barger