

**Shipping:** 123 Pawnook Farm Road • Lenoir City TN 37771

**Mailing:** P.O. Box 370 • Kingston TN 37763

**Phone:** (865) 882-5860

**Fax:** (865) 882-6394

**Website:** www.BargerAndSons.com

*Protecting the environment one tank at a time since 1967.*

Protecting the Environment

**BargerAndSons.com**

one tank at a time since 1967.

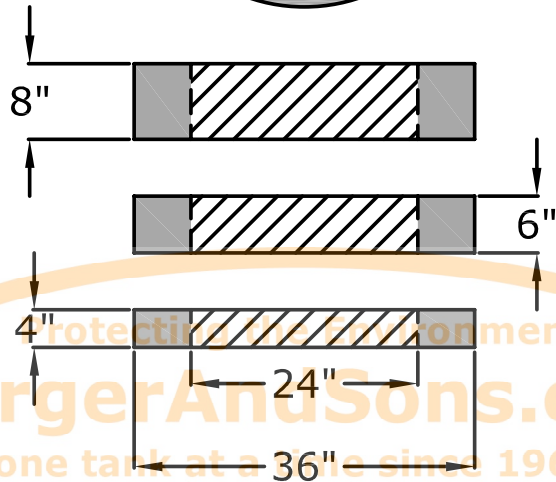
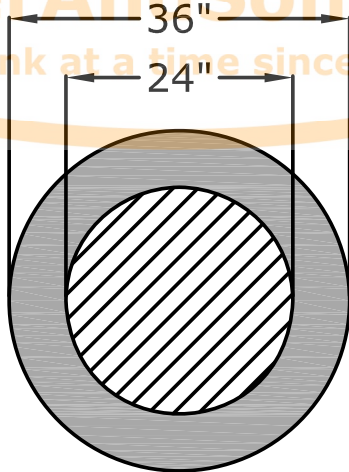

Protecting the Environment

**BargerAndSons.com**

one tank at a time since 1967.

**Grade Ring**

**Height**

4", 6", or 8" tall

**Clear Opening**

24"

**Estimated Weight**

4": 195 lbs

6": 290 lbs

8": 390 lbs

**Load Rating**

Heavy Duty

HS-20 Traffic Rated

**Type**

Precast Concrete

Protecting the Environment

**BargerAndSons.com**

one tank at a time since 1967.