

Top View

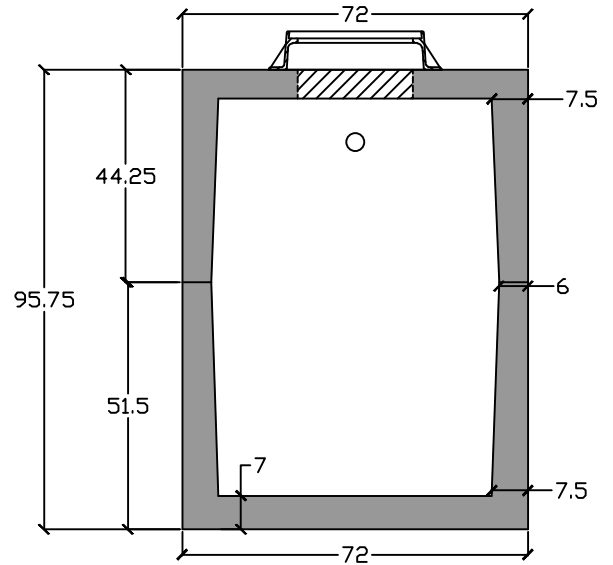

End View

- ASTM C 1613 compliant
- HS20 traffic rated
- 4" inlet/outlet (standard)
- 6" hole in baffle wall
- 2/3 - 1/3 compartment capacity

ASTM C990 compliant sealant

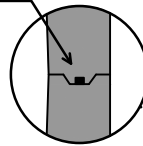

24" clear opening, Manhole Frame and Cover. Lid is labeled "Grease". Please specify vented or nonvented lid. (sold separately)

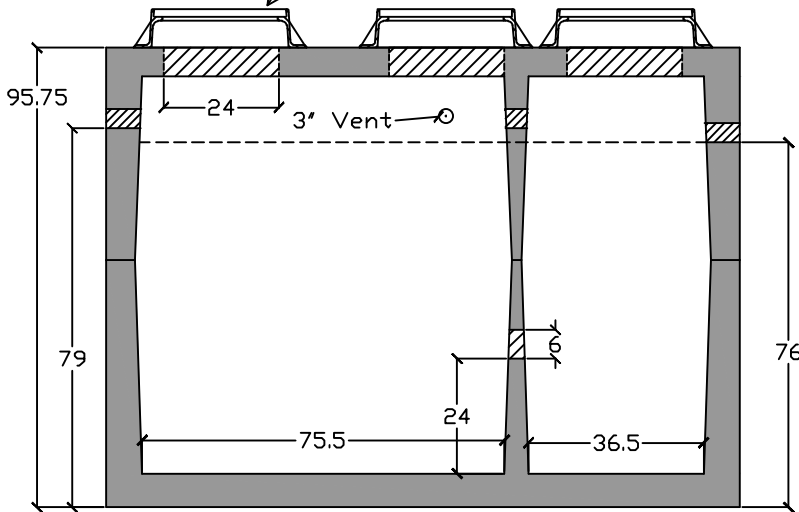

Side View

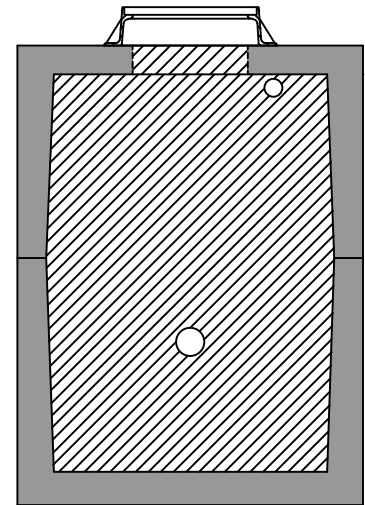

Baffle View

Specifications

Concrete: 5,000 psi minimum strength (28 day)
Reinforcing: Primary reinforcement will be rebar.
Risers: Grade rings and manhole frames and covers sold separately.
Sealant: Sealant used in the seam of the tank will meet or exceed ASTM C990.
Pipe Penetrations: Inlet and outlets are fitted with seals that meet or exceed all ASTM C923 specifications.
Partition Wall: The partition wall, if present, is poured monolithically.
Watertight: ASTM C 1227 latest revision. Tank must be tested within 3 working days of delivery.
Drawing: All measurements are accurate within ± 1 inch.

Tank Warranty: See Terms and Conditions.



Installation: The tank hole is not to be more than 18 in. longer and wider than the tank. There shall be a minimum of 6" of 3/4" stone bedding. This tank is designed for HS20 traffic loads and with a max backfill cover of 8" and a minimum of 6".

**Grease Trap HS20 2000 Gallon
Brentwood, TN**

C.R. Barger & Sons, Inc.
P.O. Box 370 - Kingston TN 37763
Phone 888.882.5860 - BargerAndSons.com

Date: 5.102010

Drawn By: Eric Barger

Approx. Weight: 32,000 lbs.