

Top View

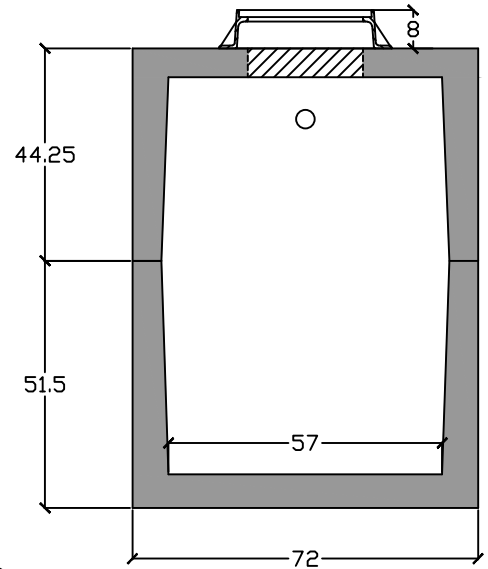

End View

- ASTM C 1613 compliant
- HS20 traffic rated
- 4" inlet/outlet (standard), larger sizes must be specified
- 6" PVC 90 in baffle wall
- 2/3 - 1/3 compartment capacity

ASTM C 990 Butyl Sealant

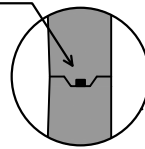

24" clear opening, H20 Manhole Frame and Cover. Lid is labeled "Grease". Please specify vented or non-vented lid.

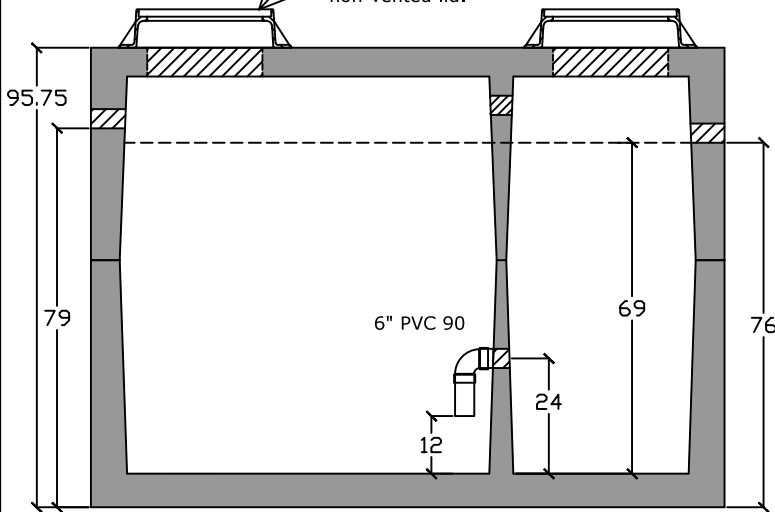

Side View

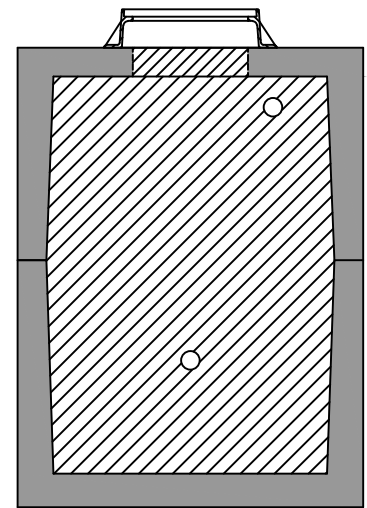

Baffle View

**Specifications**

**Concrete:** 5,000 psi minimum strength (28 day)  
**Reinforcing:** Primary reinforcement will be rebar.  
**Risers:** Grade rings and manhole frames and covers sold separately.  
**Sealant:** Sealant used in the seam of the tank will meet or exceed ASTM C990.  
**Pipe Penetrations:** Inlet and outlets are fitted with seals that meet or exceed all ASTM C923 specifications.  
**Partition Wall:** The partition wall, if present, is poured monolithically.  
**Watertight:** ASTM C 1227 latest revision. Tank must be tested within 3 working days of delivery.  
**Drawing:** All measurements are accurate within  $\pm 1$  inch.

**Tank Warranty:** When installed in accordance with manufacturer's instructions is warranted against defective materials and/or workmanship for 1 year from the date of delivery to the project site. Should a defect appear within the warranty period, C. R. Barger & Sons, Inc. will supply a new tank in replacement thereof. C. R. Barger & Sons, Inc. liability is limited to the value of the tank itself and specifically excludes the cost of installation and/or removal and consequential damages. Failure to comply with C. R. Barger & Sons, Inc. installation procedures and general notes will void warranty.



**C.R. Barger & Sons, Inc.**  
 P.O. Box 370 - Kingston TN 37763  
 Phone 888.882.5860 - BargerAndSons.com



**Installation:** The tank hole is not to be more than 18 in. longer and wider than the tank. There shall be a minimum of 6" of 3/4" stone bedding. This tank is designed for HS20 traffic loads and with a max backfill cover of 8" and a minimum of 6".

**Grease Trap HS20 2000 Gallon  
 City of Morristown, TN**

Date: 4.192012      Drawn By: Eric Barger      Approx. Weight: 30,500 lbs.