

Top View

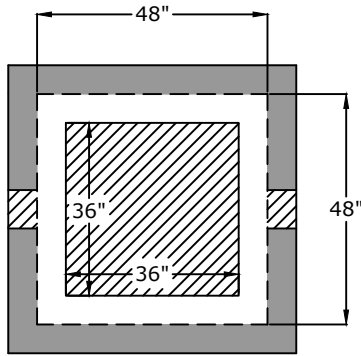

Notes

Lid weight - 1,700 lb  
 Body weight - 7,200 lb

Side View

Aluminum Hatch

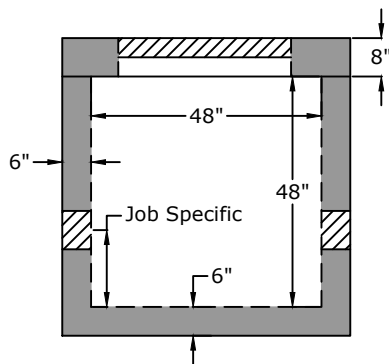

Approved for Production

Project: \_\_\_\_\_

Date: \_\_\_\_\_

Quantity: \_\_\_\_\_

By: \_\_\_\_\_

**BARGER**  
**PRECAST**

**Specifications**

**Concrete:** 5,000 psi minimum strength (28 day)

**Reinforcing:** Primary reinforcement will be a #3 rebar (Grade 60) rebar. An H-20 traffic version is available.

**Pipe Penetrations:** The inlet and outlet are fitted with solid seals (4" D.I.P. - 10" D.I.P.) unless otherwise specified. All pipe penetrations are placed according to job requirements.

**Pipe Stands:** Adjustable height pipe stands may be provided to support assembly if required

**Sealant:** Sealant used will meet or exceed ASTM C990.

**Steps:** If required, the steps will be aligned under hatch unless specified.

**4' x 4' x 4' Vault**

C.R. Barger & Sons, Inc.  
 P.O. Box 370 - Kingston TN 37763  
 Phone 888.882.5860 - BargerAndSons.com

Date: 7.202012

Drawn By: Eric Barger

Last Updated: 11.282023