

Top View

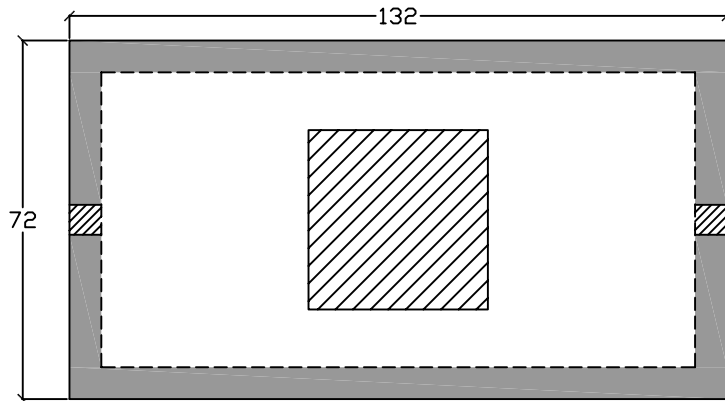

End View

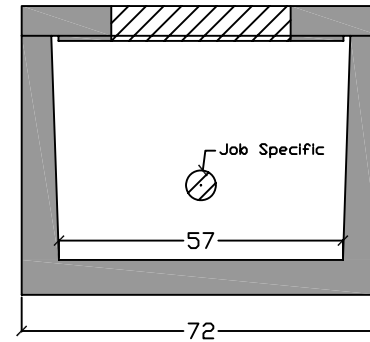

**Specifications**

**Concrete:** 5,000 psi minimum strength (28 day)

**Reinforcing:** Primary reinforcement will be a #3 rebar (Grade 60) rebar that will reinforce the sides and bottom.

**Pipe Penetrations:** All pipe penetrations are placed according to job requirements.

**Meter Box Lid:** The meter box lid will be an aluminum bilco lid with a load rating of 150 p.s.f. Lids can be drop-in-place or cast-in-place and positioned in the top according to job requirements.

Meter box lid sizes kept in stock are 3' x 3' and 4' x 6'. Other sizes available upon request.

**General:** Meter vaults are not water tight structures.

Side View

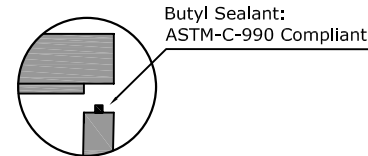
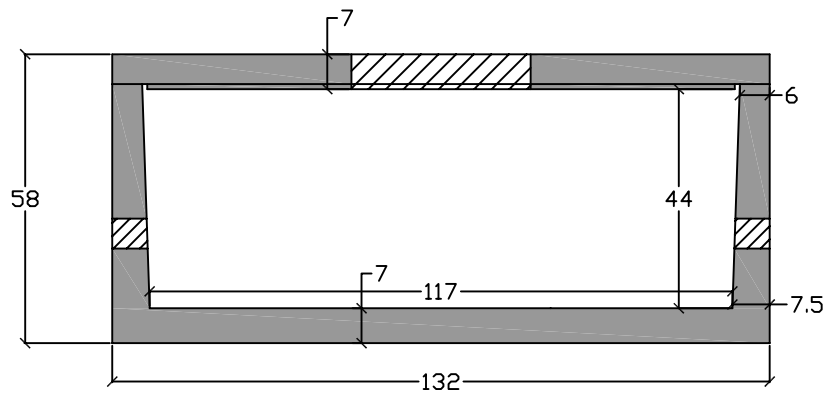

Manufactured by:  
**C.R. Barger & Sons, Inc.**  
 P.O. Box 370  
 Kingston TN 37763  
**Phone** 865.270.8080 **Fax** 865.270.8079  
 www.BargerAndSons.com

General Notes:  
 All vertical measurements are accurate within ± 1 inch on the tank. The lids can be moved and resized if necessary.

Tank Type:	Meter Pit 1000 H-20 Traffic Rated	
Date:	3.202006	Approx. Weight: 22,000 lbs.
Drawn By:	Eric Barger	Sub-type: Top Seam