

Top View

- **4" inlet/outlet (standard)**
- 2/3 - 1/3 compartment capacity

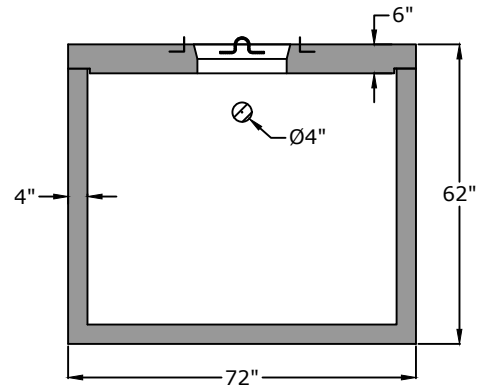

End View

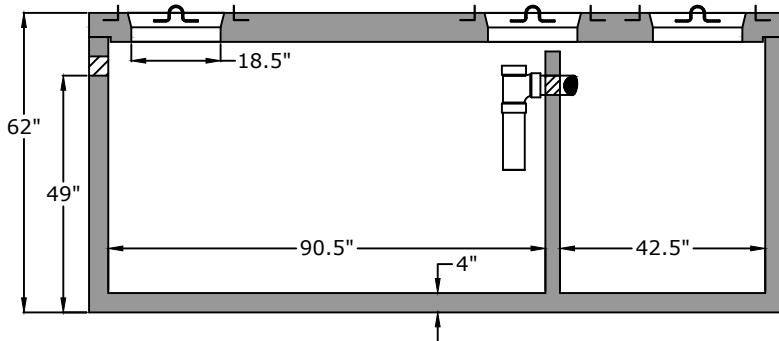
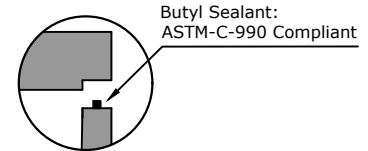

Side View

Approved for Production

Project: _____ **Date:** _____

Quantity: _____ **Signature:** _____

Specifications

Concrete: 5,000 psi minimum strength (28 day)
Reinforcing: Primary reinforcement will be rebar.
Riser Adapter Ring: Cast in place.
Sealant: Sealant used in the seam of the tank will meet or exceed ASTM C990.

Pipe Penetrations: Inlet and outlets are fitted with seals that meet or exceed all ASTM C923 specifications.
Partition Wall: The partition wall, if present, is poured monolithically.
Watertight: ASTM C 1227 latest revision. Tank must be tested within 3 working days of delivery.
Drawing: All measurements are accurate within ± 1 inch.



Weights
 Top - 5,191 lb
 Bottom - 11,262 lb

Anti-Float Protection
 22" of water

Tank Warranty: See Terms and Conditions.

Installation: The tank hole is not to be more than 18 in. longer and wider than the tank.

C.R. Barger & Sons, Inc.
 P.O. Box 370 - Kingston TN 37763
 Phone (888) 882-5860 BargerPrecast.com

City of Friendsville 1500 Pump Tank

Date: 3.252013 Drawn By: Eric Barger Last Updated: 6.222022