

Top View

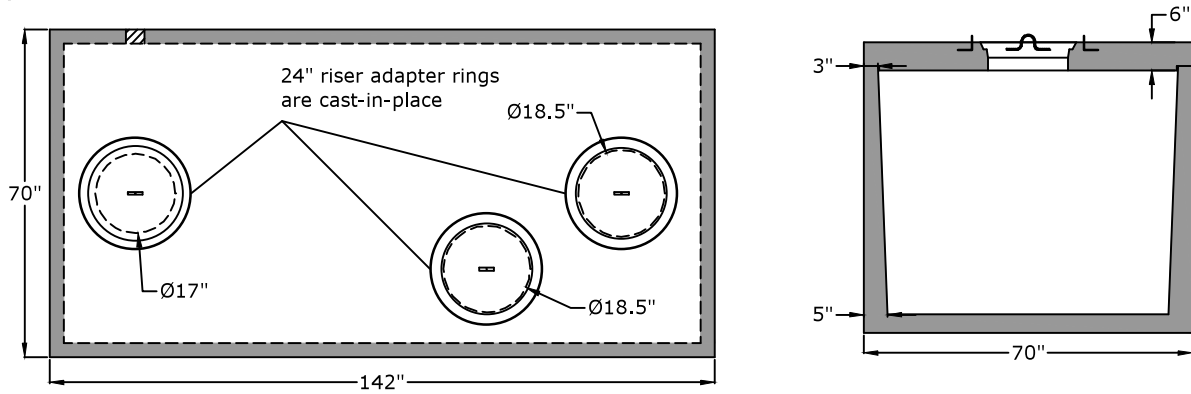

Side View

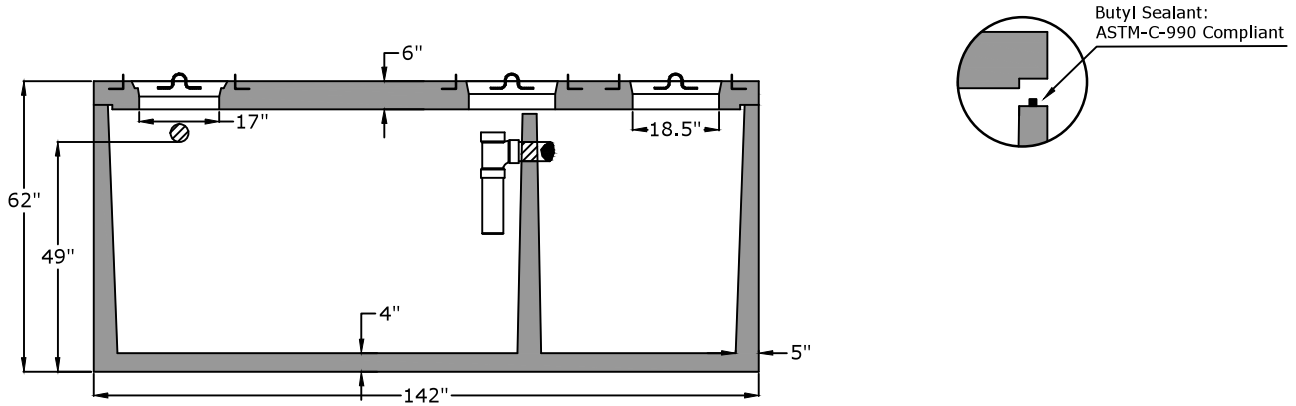

Approved for Production

Project: \_\_\_\_\_

Date: \_\_\_\_\_

Quantity: \_\_\_\_\_

By: \_\_\_\_\_

**Specifications**

- Concrete:** 5,000 psi minimum strength (28 day)
- Reinforcing:** Primary reinforcement will be rebar.
- Riser Adapter Ring:** Cast in place.
- Sealant:** Sealant used in the seam of the tank will meet or exceed ASTM C990.
- Pipe Penetrations:** Inlet and outlets are fitted with seals that meet or exceed all ASTM C923 specifications.
- Partition Wall:** The partition wall, if present, is poured monolithically.
- Watertight:** ASTM C 1227 latest revision. Tank must be tested within 3 working days of delivery.
- Drawing:** All measurements are accurate within ± 1 inch.
- Warranty:** See Terms and Conditions.



C.R. Barger & Sons, Inc.  
 P.O. Box 370 - Kingston TN 37763  
 Phone 888.882.5860 - BargerAndSons.com

**WBUD 1500 Pump Tank  
 Left Hand Inlet Configuration**

Date: 3.252013

Drawn By: EB

Approx. Vault Weight: 17,000 lbs.