

Top View

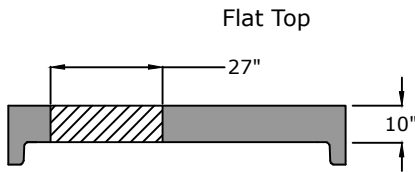

Flat Top
10" - 3,700 lb.

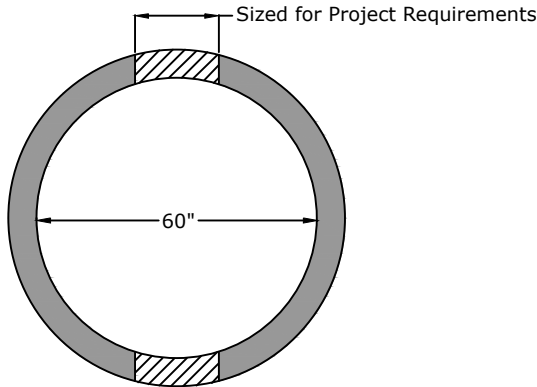
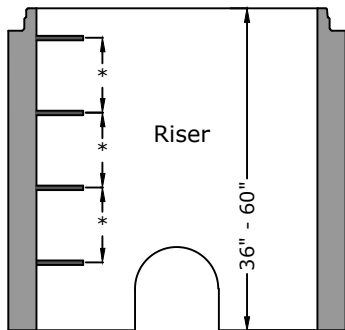

Riser Weights
36" - 3,600 lb.
48" - 5,100 lb.
60" - 6,500 lb.



Approved for Production

Project: _____

Date: _____

Quantity: _____

By: _____

**BARGER
PRECAST**

Specifications

- Concrete:** 5,000 psi minimum 28 day compressive strength
- Reinforcing:** Per ASTM C478 with design calculations performed by a Licensed P.E. Minimum 2" cover of all reinforcing steel.
- Pipe Penetrations:** All pipe penetrations are placed according to job requirements.
- Pipe Seals:** All pipe boots will meet ASTM C 923.
- Sealant:** Sealant used will meet ASTM C 990.
- Steps:** On 16" center unless otherwise specified.
- Preformed Invert:** As required by plans or governing specifications.

**60" i.d. Precast Air Release Valve
Manhole**

C.R. Barger & Sons, Inc.
P.O. Box 370 - Kingston TN 37763
Phone 888.882.5860 - BargerAndSons.com

Date: 6/27/13

Drawn By: RFB

Approx. weight: See chart