

Top View

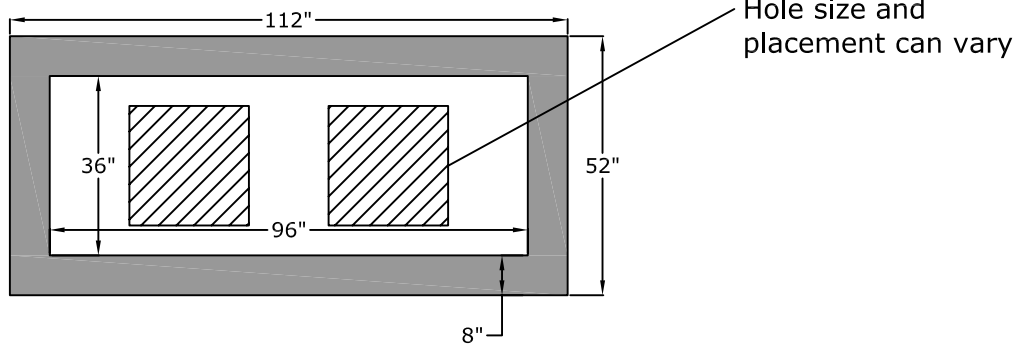

Top Lid

Height (in.)	Weight (lb.)
8"	4,000

Side View

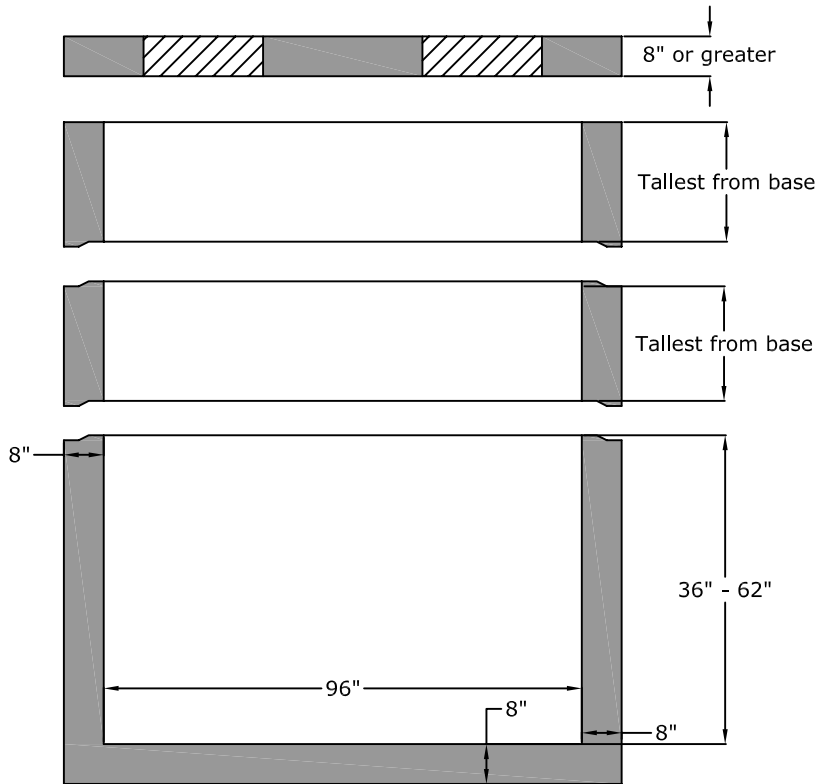

Riser Weight

Height (in.)	Weight (lb.)
36"	7,308
40"	8,120
44"	9,000
48"	9,800
52"	10,500
56"	11,400
60"	12,200
62"	12,600

Base Weight

Height (in.)	Weight (lb.)
36"	11,308
40"	12,120
44"	13,000
48"	13,800
52"	14,500
56"	15,400
60"	16,200
62"	16,600

Approved for Production

Project: _____ Date: _____

Quantity: _____ By: _____



C.R. Barger & Sons, Inc.
P.O. Box 370 - Kingston TN 37763
Phone 888.882.5860 - BargerAndSons.com

Specifications

Concrete: 5,000 psi minimum strength (28 day)
Reinforcement: ASTM C 913 Latest Edition
TDOT Reference: D-CB-14S

36" W x 96" L Area Drain, Curb Inlet, Catch Basin & General Box

Date: 5.102010 Drawn By: Eric Barger Approx. Vault Weight: See chart