

Top View

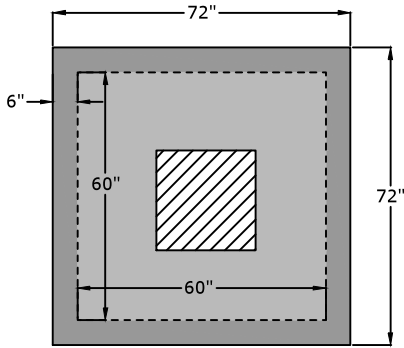

Side View

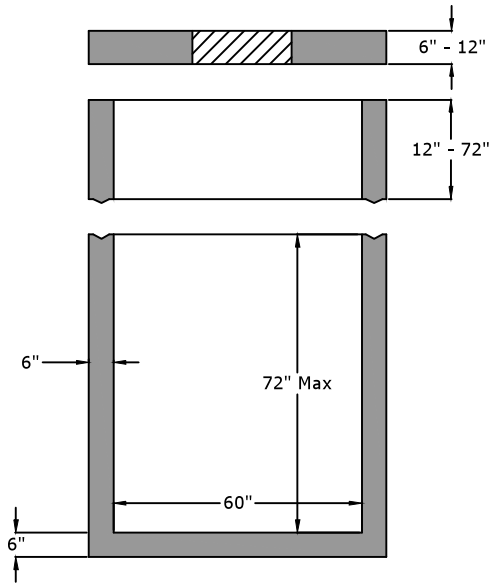

Top Lid

Height (in.)	Weight (lb.)
6"	2,600
8"	3,500

Riser Weight

Height (in.)	Weight (lb.)
12"	1,600
24"	3,200
36"	4,800
48"	6,300
60"	7,900
72"	9,500

Base Weight

Height (in.)	Weight (lb.)
12"	4,200
24"	5,800
36"	13,800
48"	8,900
60"	10,500
72"	12,500

Approved for Production

Project: _____

Date: _____

Quantity: _____

By: _____

Specifications

Concrete: 5,000 psi minimum strength (28 day)
Reinforcement: ASTM C 913 Latest Edition



C.R. Barger & Sons, Inc.
 P.O. Box 370 - Kingston TN 37763
 Phone 888.882.5860 - BargerAndSons.com

**60" x 60"
 Area Drain, Curb Inlet, Catch Basin & General Box**

Date: 4.232015

Drawn By: Eric Barger

Approx. Vault Weight: