

Top View

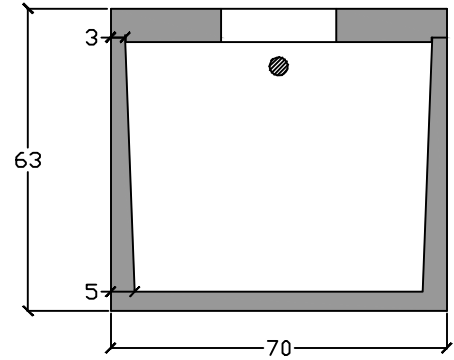

End View

- 4" inlet/outlet (standard)
- Three 4" holes in baffle wall
- 2/3 - 1/3 compartment capacity

### Stencil

[Date of manufacture]  
 1500 Gallon  
 150 lb/sq ft  
 3' of cover  
 [Inlet/Outlet Size]  
 "Inlet" and "Outlet"

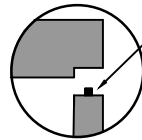

Butyl Sealant:  
 ASTM-C-990 Compliant

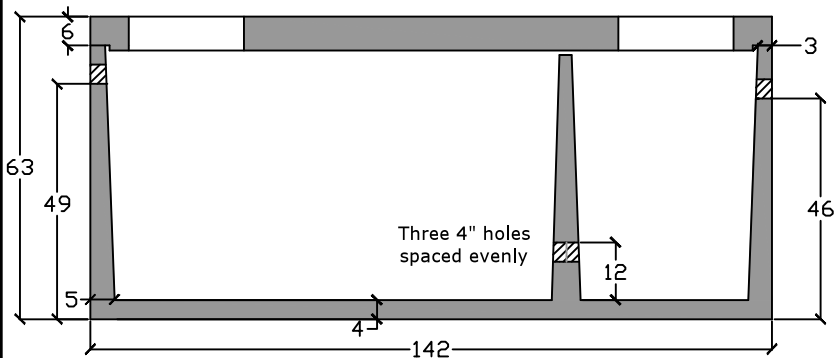

Side View

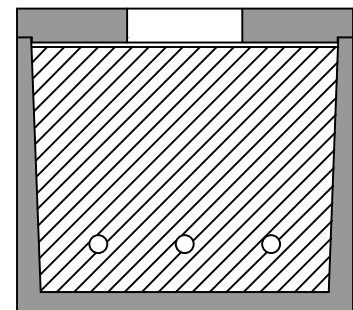

Baffle View

### Specifications

**Concrete:** 5,000 psi minimum strength (28 day)  
**Reinforcing:** Primary reinforcement will be rebar.  
**Risers:** Grade rings and manhole frames and covers sold separately.  
**Sealant:** Sealant used in the seam of the tank will meet or exceed ASTM C990.  
**Pipe Penetrations:** Inlet and outlets are fitted with seals that meet or exceed all ASTM C923 specifications.  
**Partition Wall:** The partition wall, if present, is poured monolithically.  
**Watertight:** ASTM C 1227 latest revision. Tank must be tested within 3 working days of delivery.  
**Drawing:** All measurements are accurate within ± 1 inch.

**Tank Warranty:** See Terms and Conditions.



C.R. Barger & Sons, Inc.  
 P.O. Box 370 - Kingston TN 37763  
 Phone 888.882.5860 - BargerAndSons.com

**Installation:** The tank hole is not to be more than 18 in. longer and wider than the tank. There shall be a minimum of 6" of 3/4" stone bedding. Do not install across path of vehicles or heavy equipment. This tank is designed for one hundred fifty pounds per square foot (150 lb/ft<sup>2</sup>) uniform loading on the top of the tank with a max backfill cover of 36" and a minimum of 6".

## Grease Trap 1500 Gallon Hamilton County WWTa - Hamilton County, TN

Date: 12/21/12

Drawn By: Eric Barger

Approx. Weight:

16,000 lbs.