

**Top View**

- ASTM C 1613 compliant
- HS20 traffic rated
- 4" inlet/outlet (standard)
- 4" PVC 90 in baffle wall
- 2/3 - 1/3 compartment capacity

ASTM C 990 Butyl Sealant

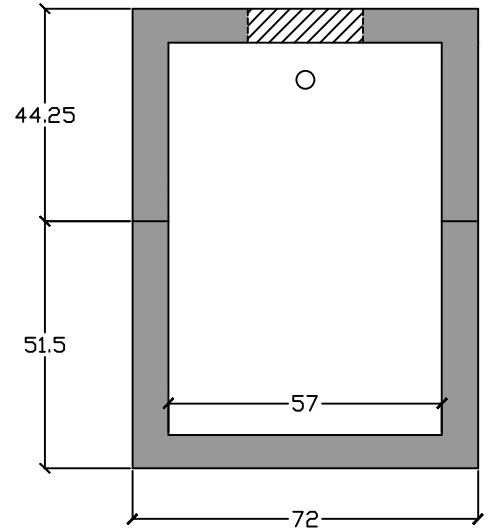
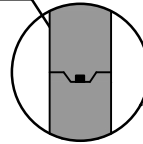

**End View**

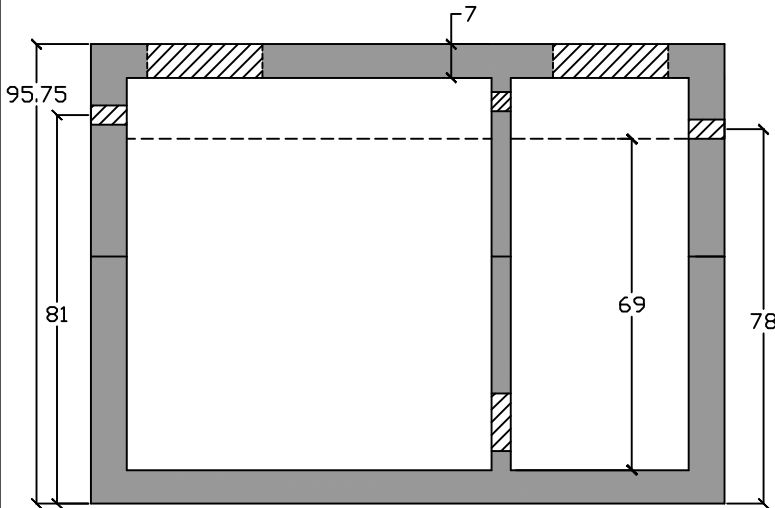

**Side View**

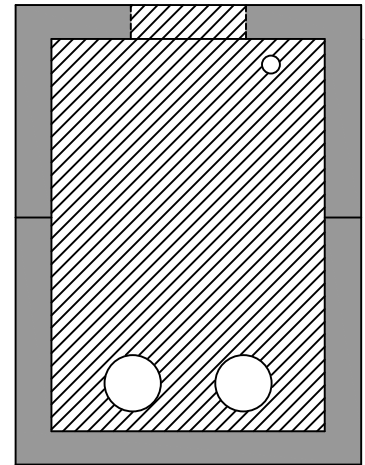

**Baffle View**

**Specifications**

**Concrete:** 5,000 psi minimum strength (28 day)  
**Reinforcing:** Primary reinforcement will be rebar.  
**Risers:** Grade rings and manhole frames and covers sold separately.  
**Sealant:** Sealant used in the seam of the tank will meet or exceed ASTM C990.  
**Pipe Penetrations:** Inlet and outlets are fitted with seals that meet or exceed all ASTM C923 specifications.  
**Partition Wall:** The partition wall, if present, is poured monolithically.  
**Watertight:** ASTM C 1227 latest revision. Tank must be tested within 3 working days of delivery.  
**Drawing:** All measurements are accurate within  $\pm 1$  inch.

**Tank Warranty:** See Terms and Conditions.

**BARGER**  
**PRECAST**

**Weights**  
 Top - 16,000 lb  
 Bottom - 17,500 lb

**Anti-Float Protection**  
 5" of water

**Installation:** The tank hole is not to be more than 18 in. longer and wider than the tank. There shall be a minimum of 6" of 3/4" stone bedding. This tank is designed for HS20 traffic loads and with a max backfill cover of 8" and a minimum of 6".

C.R. Barger & Sons, Inc.  
 P.O. Box 370 - Kingston TN 37763  
 Phone 888.882.5860 - BargerAndSons.com

**Grease Trap HS20 2000 Gallon**  
**West Knox Utility District**

Date: 5.102021

Drawn By: Eric Barger