

Top View

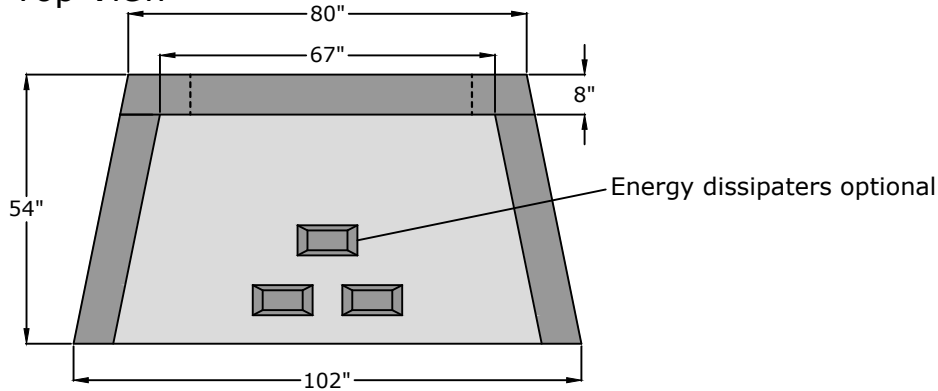

Hole Dia. (in.)	Weight (lb.)
34"	6,961
38"	6,806
44"	6,541
50"	6,238
55"	5,955
Toe	Add 760

Front View

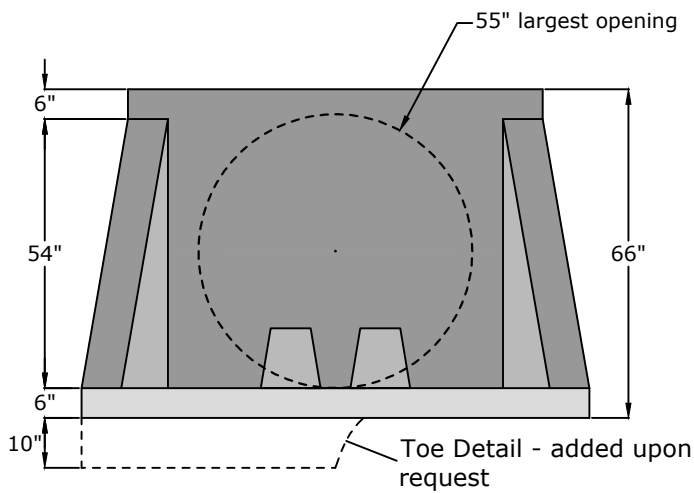

PIPE SIZE:	
HOLE SIZE:	
Toe:	Yes No

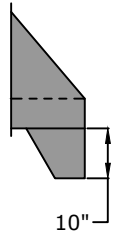

Toe Detail - added upon request

Approved for Production

Project: _____

Date: _____

Quantity: _____

By: _____

BARGER
PRECAST

Specifications

Concrete: 5,000 psi minimum strength (28 day)
Reinforcement: #3 rebar (Grade 60) or 0.12 in² WWF
Energy Dissipaters: Added upon request (12"L x 6"W x 12"H)
Toe: Added upon request

Headwall Medium

C.R. Barger & Sons, Inc.
 P.O. Box 370 - Kingston TN 37763
 Phone 888.882.5860 - BargerAndSons.com

Date: 11.022017 Drawn By: Eric Barger Approx. Weight: See above