

Top View

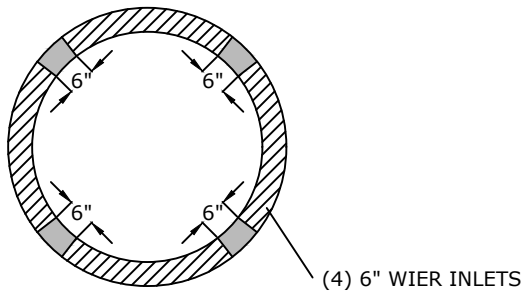

Flat Top

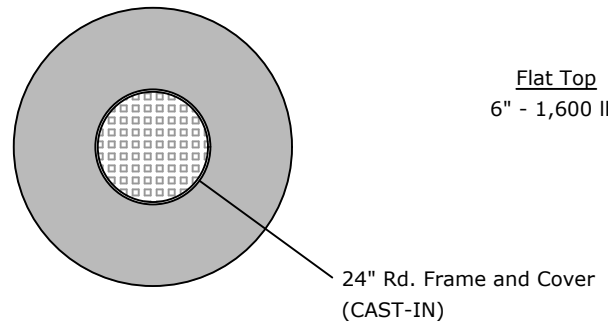
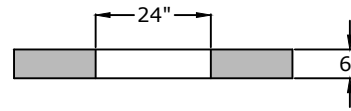

Flat Top
6" - 1,600 lb.

Side View

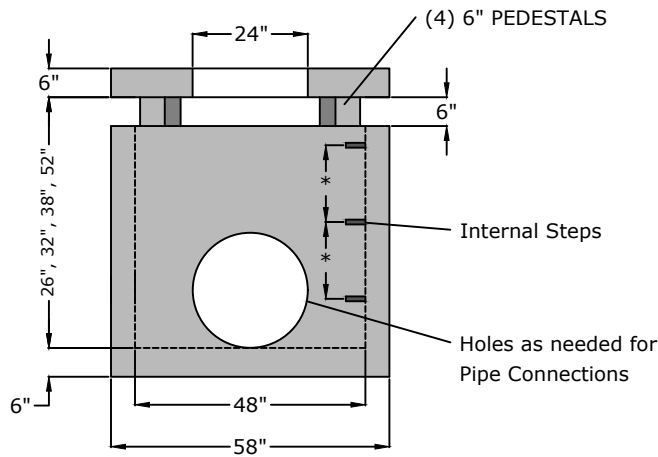

Monolithic base

Approved for Production

Project: _____ **Date:** _____

Quantity: _____ **By:** _____

BARGER
PRECAST

Specifications

Concrete: 4,500 psi minimum 28 day compressive strength
Reinforcing: Per ASTM C478 with design calculations performed by a Licensed P.E. Minimum 2" cover of all reinforcing steel.
Pipe Penetrations: All pipe penetrations are placed according to job requirements.
Pipe Sealant: Pipes to be sealed into structure with grout.
Sealant: Sealant used will meet ASTM C923.
Steps: On 16" centers unless otherwise specified.

48" I.D. Drop Inlet
ASTM C-478 Compliant

C.R. Barger & Sons, Inc.
P.O. Box 370 - Kingston TN 37763
Phone 888.882.5860 - BargerAndSons.com

Date: 3.142023 Drawn By: Eric Barger