

Top View

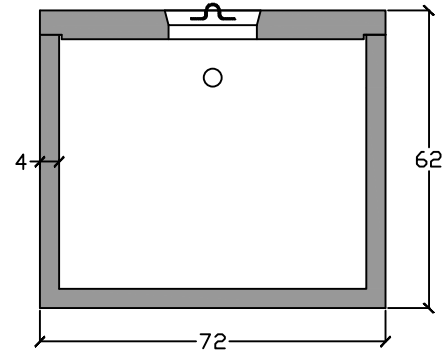

End View

- **4" inlet/outlet (standard)**
- 2/3 - 1/3 compartment capacity

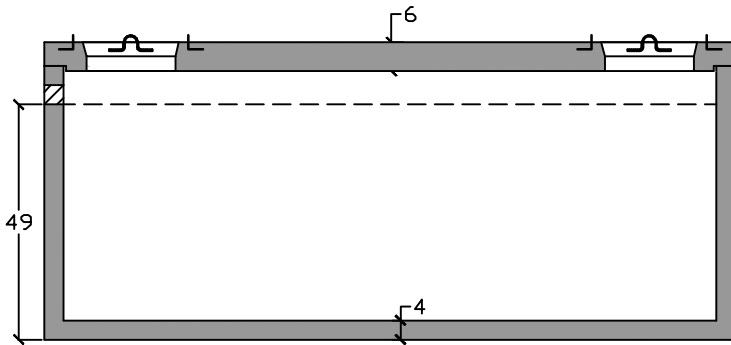

Side View

**Specifications**

**Concrete:** 5,000 psi minimum strength (28 day)  
**Reinforcing:** Primary reinforcement will be rebar.  
**Risers:** Grade rings and manhole frames and covers sold separately.  
**Sealant:** Sealant used in the seam of the tank will meet or exceed ASTM C990.  
**Pipe Penetrations:** Inlet and outlets are fitted with seals that meet or exceed all ASTM C923 specifications.  
**Partition Wall:** The partition wall, if present, is poured monolithically.  
**Watertight:** ASTM C 1227 latest revision. Tank must be tested within 3 working days of delivery.  
**Drawing:** All measurements are accurate within ± 1 inch.

**Tank Warranty:** See Terms and Conditions.

**BARGER  
PRECAST**

**Weights**  
 Top - 5,200 lb  
 Bottom - 11,500 lb

**Anti-Float Protection**  
 22" of water

**Installation:** The tank hole is not to be more than 18 in. longer and wider than the tank. There shall be a minimum of 6" of 3/4" stone bedding. Do not install across path of vehicles or heavy equipment. This tank is designed for one hundred fifty pounds per square foot (150 lb/ft<sup>2</sup>) uniform loading on the top of the tank with a max backfill cover of 36" and a minimum of 6".

**1500 Gallon Pump Tank**

**C.R. Barger & Sons, Inc.**  
 P.O. Box 370 - Kingston TN 37763  
 Phone 888.882.5860 - BargerAndSons.com

Date: 8.122020 Updated: 8.122020 Drawn By: Eric Barger